

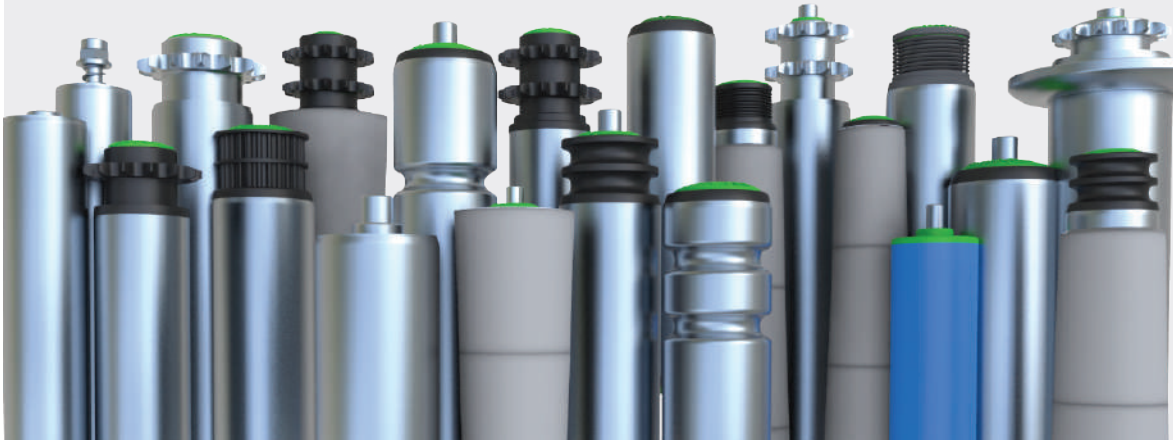

**Conveline**<sup>®</sup>  
*Inspired by Excellence*



BEST QUALITY  
& DURABLE  
PERFORMANCE



QUICK SHIPPING /  
FAST DELIVERY



HIGH QUALITY  
ASSURANCE

# CONVEYOR ROLLERS

**eBOOK**

**HIGH QUALITY CONVEYOR ROLLERS**  
INDIA'S LARGEST ROLLER MANUFACTURER

[www.convelinerollers.com](http://www.convelinerollers.com)



## THE COMPANY

Since its establishment in 2014, Conveline has always been committed to provide the highest quality conveyors, intralogistics conveyors, its parts and components to a wide range of industries. Today, industries' requirement for fast & efficient movement of their goods, choosing a correct roller as per their requirement is very difficult. Looking at this, Conveline Systems Pvt. Ltd. has launched an extensive range of Conveyor Rollers which is beneficial for various industrial requirements.

Today, we are the largest manufacturer of Rollers in India, operating from a 80,000 sq. ft. manufacturing facility. Our dedication to manufacture quality rollers, its parts and components is evident by the technical innovation we bring to the fore. Our manufacturing expertise and outstanding customer service have remained our commitment to provide best in class experience to our customers.

We have expertise and experience in all the most challenging applications in industries. We are specialists of wide range of rollers such as stainless steel, zinc plated mild steel and PVC, with tube diameters ranging from 25mm to 89mm. Conveline Systems is well known in Gravity Conveyor Rollers, Fixed Driven Rollers, Grooved Conveyor Rollers, Tapered Conveyor Rollers, Accumulation Conveyor Rollers and many more.

Conveline has delivered & served customized quality products to industries such as Air & Cargo, Post & Parcel, Pharmaceutical, Food & Agriculture, Logistics & Warehouse, Packaging, General Manufacturing and many more.

Partnering with us will enhance your competitiveness and continue to allow the manufacturing community to prosper.

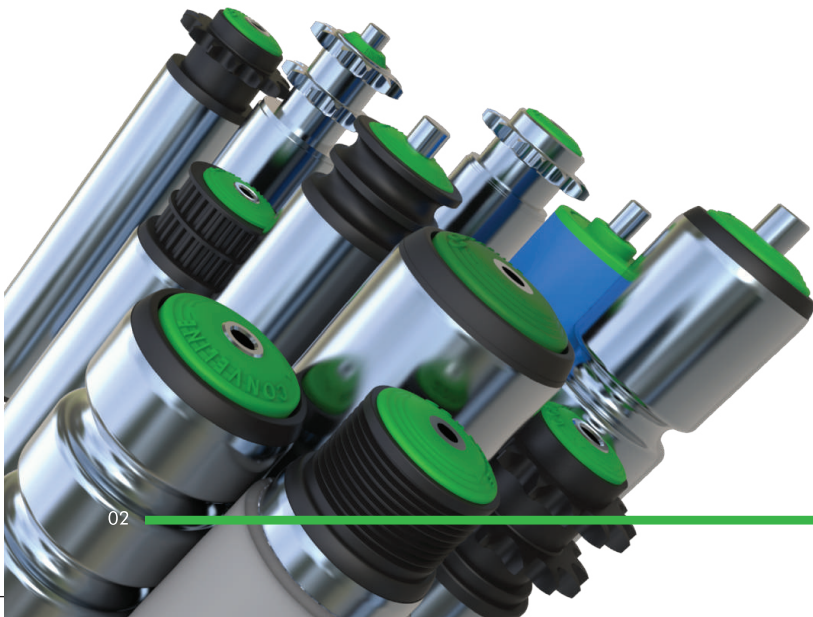

## ABOUT CONVELINE ROLLERS

### HIGH QUALITY ROLLERS AT THE RIGHT PRICE

Our huge quantities of raw materials in stock let us maintain stable prices of our solutions and we can offer our products at a reasonably lower rate than the market prices. We can even offer better prices if for you have requirement of larger quantities. Our continuous investment in technology enables us to improve upon our cost and the same can be passed on to our customers.

Conveline Systems is specialist of wide range of rollers such as stainless steel, zinc plated mild steel and PVC, with tube diameters ranging from 25mm to 89mm.

### QUALITY DESIGN AND BUILD

At Conveline, through our different stages of quality checking, we always make sure that the product is best in class and as per our customers' requirements.

We have the capacity to  
manufacture over

**10,00,000+**

rollers per annum  
and all our  
manufacturing processes  
are controlled and  
undertaken in-house in  
strict accordance to our  
Quality Standards.



### CUSTOMER SERVICE

Conveline Systems aims to provide world class conveyor roller by providing the best-in-class products and best possible support to our customers globally. Our staff consists of dedicated project engineers, production and application teams and they are ready to provide fast and effective support. Our Highly skilled team ensures that your material handling automation is running at peak performance for maximum productivity.

# INDEX

Page

## ROLLER OVERVIEW

---

6-9

Roller selection	6-6
Load capacity	7-7
Run out	7-7
Tube & Shaft	7-9
Bearing	9-9
Roller Order code	9-9

## GRAVITY ROLLER SERIES

---

10-22

1101 Series – Light duty PVC conveyor roller	11-12
1102 Series – Universal conveyor roller	13-17
1103 Series – Gravity conveyor roller with steel housing	18-22

## POWERED ROLLER SERIES

---

23-45

1201 Series – Single grooved conveyor roller	24-27
1202 Series – Double grooved conveyor roller	24-27
1203 Series – O belt pulley conveyor roller	28-29
1204 Series – Poly vee belt pulley conveyor roller	30-31
1205 Series – Timing belt pulley conveyor roller	32-33
1206 Series – Polymer single sprocket conveyor roller	34-36
1207 Series – Polymer double sprocket conveyor roller	34-36
1208 Series – Steel single sprocket conveyor roller	37-40
1209 Series – Steel double sprocket conveyor roller	37-40
1210 Series – Steel single sprocket conveyor roller with steel housing	41-45
1211 Series – Steel double sprocket conveyor roller with steel housing	41-45

## INDEX

Page

### ACCUMULATION ROLLER SERIES

**46–53**

1301 Series – Polymer single sprocket accumulation roller	47-48
1302 Series – Polymer double sprocket accumulation roller	47-48
1303 Series – Steel single sprocket accumulation roller	49-50
1304 Series – Steel double sprocket accumulation roller	49-50
1305 Series – Steel single sprocket adjustable accumulation roller	51-53
1306 Series – Steel double sprocket adjustable accumulation roller	51-53

### CURVE ROLLER CONVEYOR SERIES

**54–69**

1401 Series – Gravity tapered sleeve roller	56-58
1402 Series – Double grooved tapered sleeve roller	59-61
1403 Series – Double grooved O belt pulley tapered sleeve roller	62-64
1404 Series – Poly vee belt tapered sleeve roller	65-67
1405 Series – Polymer sprocket tapered sleeve roller	68-69

### CONVEYOR COMPONENTS

**70–71**

Ball Transfer	70-71
Skate wheel	70-71
Flow wheel rack	70-71
O – Ring	70-71
PU Sleeve	70-71

# ROLLER OVERVIEW

## CONVEYOR ROLLER SELECTION

1. Check whether your product is suitable for roller conveyor?
  - > A product with hard and flat bottom surface are suitable for roller conveyor system such as cartons, bins, flat bottom plastic boxes, metal bins, drums, wooden pallets, plastic pallets, buckets etc.
  - > Product with irregular shapes are not suitable for roller conveyor system.
  - > Product with point or line contact are also not suitable for roller conveyor system as it may damage the rollers.
2. Check environment before selection of rollers?
  - > Plastic components in the rollers cannot sustain very high or low temperature, so check characteristics for each rollers before selecting.
  - > Rusty environment with high humidity is not suitable for zinc coated rollers, because after a certain period it may get rusty.

3. Roller length selection?
  - > Conveyor roller length is selected according to width of product. For straight conveying, roller length is calculated from  $W = B + \Delta B$ 
    - W = Length of roller
    - B = Product width
    - $\Delta B$  = Additional width required (Generally 50 to 150mm)

- > For curve conveyor calculate the width according to inner radius and product dimensions, further details has been given on the curve roller conveyor page.
- > For products which is having very hard and sturdy base, the width of product can exceed the length of roller with calculation formula  $W \geq 0.8B$

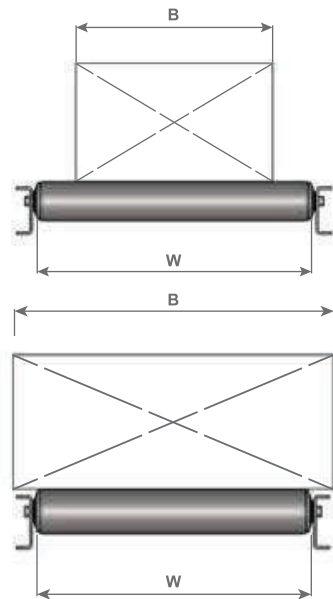

4. Roller pitch selection?
  - > Conveyor roller pitch is very important factor for steady conveying of product. For steady product conveying roller pitch  $T = 1/4 \sim 1/5 L$  or smaller.
  - > Roller pitch also effects roller conveyor weight carrying capacity, so selection of roller conveyor pitch is an important factor.

## ROLLER OVERVIEW

### LOAD CAPACITY

- > Roller load capacity mainly depends on roller tube, shaft and bearing. If product load is excessive compared to roller weight carrying capacity than it may damage the tube during the operation which may lead to unstable conveying of the product.
- > Similarly, if the load capacity of shaft is not sufficient, it may affect the running performance of conveyor system. Excessive load will also reduce the life span of bearings.
- > In this catalogue, mentioned load carrying capacity of single roller is the uniform distributed load on the roller surface (not point load).
- > The method of mounting shaft to conveyor frame also affects the overall load capacity. For example, internal threaded shaft has a higher load capacity than a loose mounted shaft such as a spring loaded shaft.

### RUN OUT

- > Conveline rollers utilise the high quality materials and strict manufacturing process to ensure better run out.
- > Check following roller runout table compared to its length. Choose the maximum data from three points on roller as the inspection data for Run out measurement

ROLLER LENGTH	ROLLER	TAPERED ROLLER
100 ~ 500	0.5	0.7
>500 ~ 1000	0.6	0.9
>1000 ~ 1600	1.0	1.4
>1600 ~ 2000	1.2 +	-

### TUBE

- > Conveline is having mainly all material tubes which are commonly used in roller manufacturing process like,

#### **Steel or Mild Steel**

- > Most widely used tube material in all general application areas.

#### **Stainless Steel**

- > Stainless steel is having good corrosion resistance and much more durable than common mild steel tubes.

#### **Aluminium**

- > It is generally used in lightweight product conveying application. It weighs only 36% of steel tube and features rust proof property.

#### **PVC**

- > It is having very low load carrying capacity compared to steel but having some features like easy cleaning, corrosion resistance, good chemical stability, low weight, low noise, shockproof etc.

# ROLLER OVERVIEW

## COMMON TUBE SIZE:

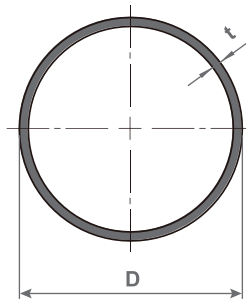

D	T
25	1.2
38	1.2
50	1.5
	2
60	2
76	3
89	3

## TUBE SURFACE TREATMENT

### Zinc Plated

- > Zinc plating does not have strong resistance to abrasion. It will wear gradually during the operation
- > Food is not permitted to come in direct contact with zinc plated surfaces

### Hard chrome plating

- > Excellent abrasion resistance
- > Food is not permitted to come in direct contact with zinc plated surfaces.

### PVC sleeve

- > It is used for reducing product slip on the conveyor and reduced conveying noise
- > PVC sleeve is similar to rubber lagging in the area of increased friction, product bottom surface protection and reduced noise. It is also cost effective than lagging
- > PVC sleeve thickness will be 2mm. Colour - Grey
- > It is not food grade material. Suitable temperature is -25° C to 50° C

## ROLLER OVERVIEW

### SHAFT

- > Shaft is the main component for load carrying, so conveline chooses high quality carbon structural steel shaft as a material.

#### Shaft size

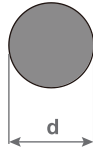

Round shaft (mm): d  
= ø8, ø10, ø12, ø14, ø15, ø20

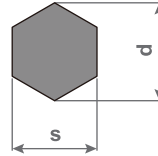

Hexagonal Shaft (mm): S  
= 11 and d = ø12

- > The standard mild steel shaft surface treatment of zinc plated. Stainless steel 304 shaft only used in the SS304 rollers. If needed special shaft, please specify during the inquiry.

### BEARINGS

- > Bearings are the critical components for any rollers, so correct choice of bearings are important factor for roller life.
- > Conveline uses its own make different types of precision sealed bearings for rollers.

### PART NUMBER FOR ORDERING

Example      1204 – SHN – ABS – 600 – 663  
                    ①           ②           ③           ④           ⑤

#### ① Roller Series Number

- > 11 – gravity roller series
- > 12 – Powered roller series
- > 13 – Curve roller series

#### ② Pipe Details

#### ③ Shaft Details

#### ④ Roller Width

- > Roller length is roller theoretical working surface, it may vary for different types of rollers. Use W to indicate the roller width

#### ⑤ Shaft Length

- > Shaft length is roller shaft length and it is indicated by L

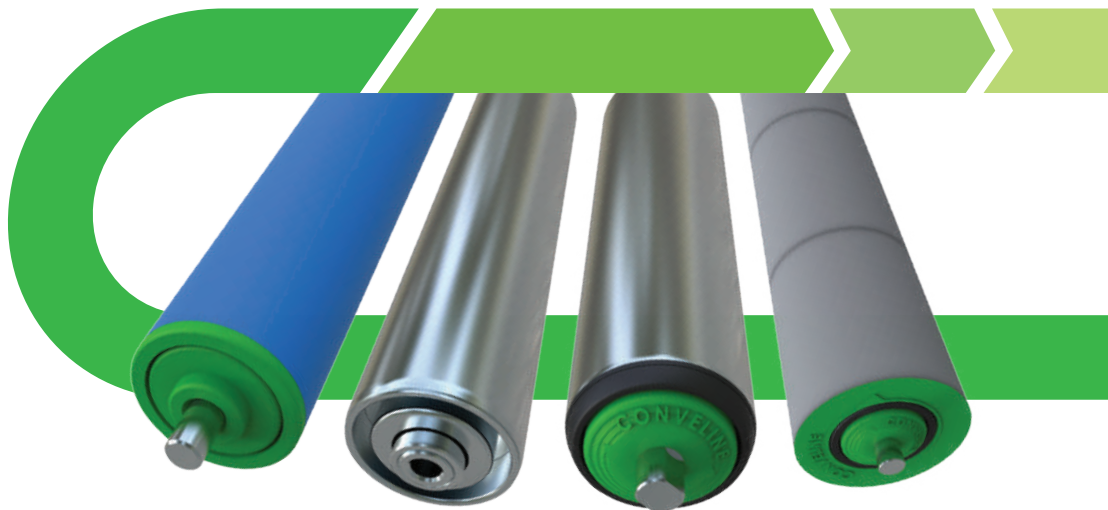

## GRAVITY ROLLERS

Series	Product Features	Diameter Range
1101	PVC tube, polyamide bearing housing, light duty conveyor rollers	25, 38, 50
1102	Light and medium duty universal conveyor rollers, polyamide bearing housing	25, 38, 50, 60, 76, 89
1103	Gravity conveyor rollers, steel bearing housing	50, 76, 89

## 1101 Series

### LIGHT DUTY CONVEYOR ROLLERS

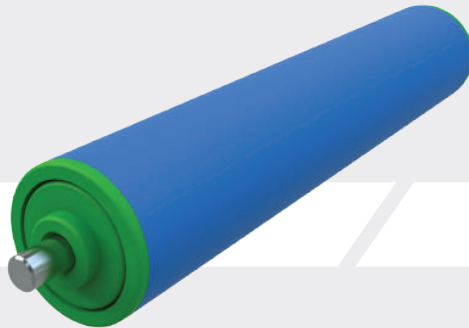

#### PRODUCT FEATURES

- > Very light weight and smooth running
- > Suitable for light weight products
- > PVC tube with good chemical stability
- > Temperature range: -5° C to + 50° C
- > Bearing Housing – POM

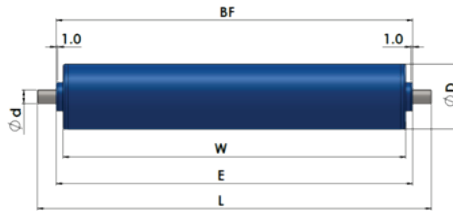

### 1101 Series – Spring Loaded

Tube Dia. (D)	Shaft Dia. (d)			
ø25	ø8	$E = W + 7$	$BF = W + 8$	$L = W + 28$
ø38	ø10	$E = W + 9$	$BF = W + 10$	$L = W + 30$
ø50	ø12	$E = W + 7$	$BF = W + 8$	$L = W + 28$

Tube	D*T	Shaft Dia.		
		ø8	ø10	ø12
ø25	ø8	$E = W + 7$	$BF = W + 8$	$L = W + 28$
ø38	ø10	$E = W + 9$	$BF = W + 10$	$L = W + 30$
ø50	ø12	$E = W + 7$	$BF = W + 8$	$L = W + 28$

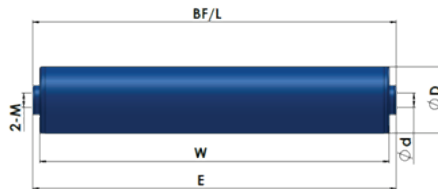

### 1101 Series – Internal Thread

Tube Dia. (D)	Shaft Dia. (d)			
ø50	ø12	$E = W + 7$	$BF = W + 8$	$L = W + 28$

Tube	D*T	Shaft Dia.		
		ø8	ø10	ø12 (M8X15)
PVC	ø50x1.5			1101-PHN-BBI

## 1102 Series

### UNIVERSAL CONVEYOR ROLLERS



#### PRODUCT FEATURES

- > It is widely used and most popular conveyor in gravity roller series
- > Generally used in carton and crate conveying application
- > Suitable for high-speed application
- > Conveline make Precision ball bearings
- > Temperature range: -5° C to + 50° C
- > Bearing Housing – Polyamide black
- > End Housing - Green

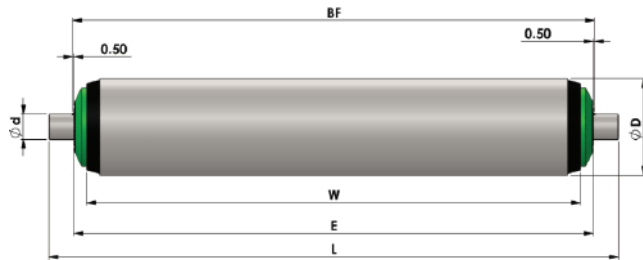

### 1102 Series – Spring loaded

Tube Dia. (D)	Shaft Dia. (d)			
ø38	ø10	E = W+10	BF = W+11	L = W+31
ø50	ø12/11hex/ø14	E = W+10	BF = W+11	L = W+31
ø60	ø15	E = W+8	BF = W+9	L = W+31

Tube	D*T	Shaft Dia.				
		ø8	11 HEX	ø12	ø14	ø15
Steel, Zinc plated	38x1.2	1102-SDN -AES				
	50x1.5		1102-SHN-AFS	1102-SHN-ABS	1102-SHN-AJS	
	50x2.0				1102-SWN-AJS	
	60x2.0					1102-SON-AKS
Steel, Zinc plated with PVC sleeve	50x1.5		1102-SRS-AFS	1102-SRS-ABS	1102-SRS-AJS	
Stainless Steel (SS304)	38x1.2	1102-KDN -BES				
	50x1.5		1102-KHN-BFS	1102-KHN-BBS	1102-KHN-BJS	
	50x2.0				1102-KWN-BJS	
	60x2.0					1102-KON-BKS
Aluminium	50x1.5		1102-AHN-AFS	1102-AHN-ABS	1102-AHN-AJS	
	60x2.0					1102-AON-AKS
PVC	50x2.0				1102-PWN-BJS	

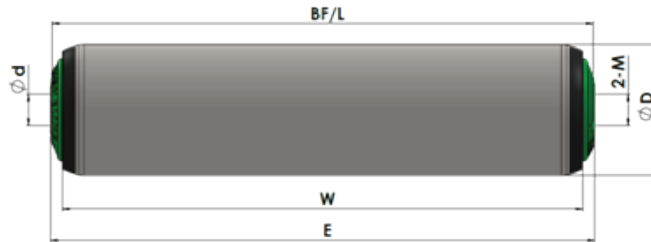

### 1102 Series – Internal Thread

Tube Dia. (D)	Shaft Dia. (d)			
ø38	ø10	E = W+10	BF = W+11	L = W+11
ø50	ø12/ø14	E = W+10	BF = W+11	L = W+11
ø60	ø15	E = W+8	BF = W+9	L = W+9
ø76	ø20	E = W+6	BF = W+7	L = W+7
ø89	ø20	E = W+10	BF = W+11	L = W+11

Tube	D*T	Shaft Dia.				
		ø10 (M6X10)	ø12 (M8x20)	ø14 (M8x20)	ø15 (M10x20)	ø20 (M12x20)
Steel, Zinc plated	38x1.2	1102-SDN -AEI				
	50x1.5		1102-SHN-ABI	1102-SHN-AJI		
	50x2.0			1102-SWN-AJI		
	60x2.0				1102-SON-AKI	
	76x3.0					1102-SPN-ALI
89x3.0					1102-SQN-ALI	
Steel, Zinc plated with PVC sleeve	50x1.5		1102-SRS-ABI	1102-SRS-AJI		
Stainless Steel (SS304)	38x1.2	1102-KDN -BEI				
	50x1.5		1102-KHN-BBI	1102-KHN-BJI		
	50x2.0			1102-KWN-BJI		
	60x2.0				1102-KON-BKI	
76x3.0					1102-KPN-BLI	
Aluminium	50x1.5		1102-AHN-ABI	1102-AHN-AJI		
	60x2.0				1102-AON-AKI	
PVC	50x2.0			1102-PWN-BJI		

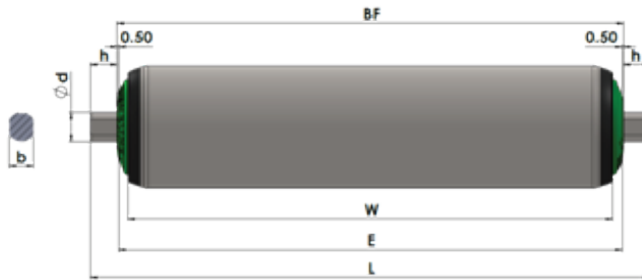

### 1102 Series – Milled Shaft

Tube Dia. (D)	Shaft Dia. (d)			
ø38	ø10	E = W+10	BF = W+11	L = W+31
ø50	ø12/ø14	E = W+10	BF = W+11	L = W+31
ø60	ø15	E = W+8	BF = W+9	L = W+29
ø76	ø20	E = W+6	BF = W+7	L = W+37
ø89	ø20	E = W+10	BF = W+11	L = W+41

Tube	D*T	Shaft Dia.				
		ø10 (b/h=8/9)	ø12 (b/h=10/11)	ø14 (b/h=12/11)	ø15 (b/h=12/11)	ø20 (b/h=16/15)
Steel, Zinc plated	38x1.2	1102-SDN -AEI				
	50x1.5		1102-SHN-ABM	1102-SHN-AJM		
	50x2.0			1102-SWN-AJM		
	60x2.0				1102-SON-AKM	
	76x3.0					1102-SPN-ALM
89x3.0					1102-SQN-ALM	
Steel, Zinc plated with PVC sleeve	50x1.5		1102-SRS-ABM	1102-SRS-AJM		
Stainless Steel (SS304)	38x1.2	1102-KDN -BEM				
	50x1.5		1102-KHN-BBM	1102-KHN-BJM		
	50x2.0			1102-KWN-BJM		
	60x2.0				1102-KON-BKM	
	76x3.0					1102-KPN-BLM
Aluminium PVC	50x1.5		1102-AHN-ABM	1102-AHN-AJM		
	60x2.0				1102-AON-AKM	
	50x2.0			1102-PWN-BJM		

## 1102 Series – Load Capacity

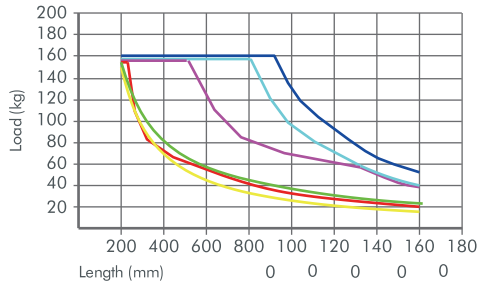
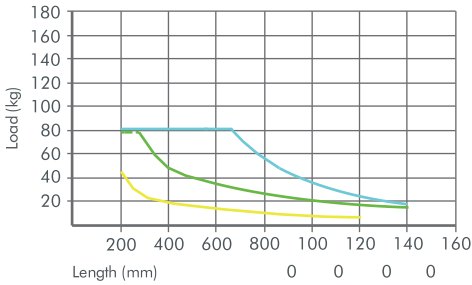

- Steel tube Ø38x1.2, Shaft Ø10, internal thread
- Steel tube Ø38x1.2, Shaft Ø10, spring loaded
- Steel tube Ø38x1.2, Shaft Ø10, milled finish

- Steel tube Ø50x1.5, Shaft Ø12, spring loaded
- Steel tube Ø50x1.5, Shaft Ø12, internal thread
- Steel tube Ø50x1.5, Shaft Ø12, milled finish
- Steel tube Ø50x1.5, Shaft Ø11hex, spring loaded
- Steel tube Ø50x2.0, Shaft Ø14, spring loaded
- Steel tube Ø50x2.0, Shaft Ø14, internal thread

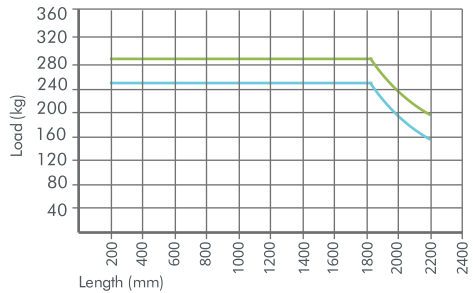
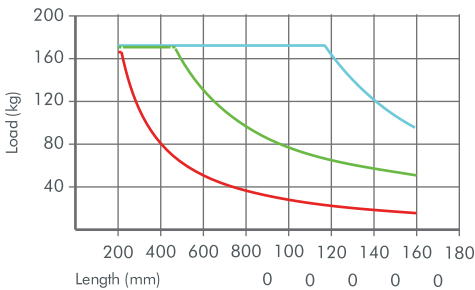

- Steel tube Ø60x2.0, Shaft Ø15, spring loaded
- Steel tube Ø60x2.0, Shaft Ø15, internal thread
- Steel tube Ø60x2.0, Shaft Ø15, milled finish

- Steel tube Ø76x3.0, Shaft Ø20, internal thread
- Steel tube Ø89x3.0, Shaft Ø20, internal thread

\* Above data shows the static load capacity of the roller for a uniformly distributed load.

## 1103 Series

### GRAVITY CONVEYOR ROLLER WITH STEEL HOUSING



#### PRODUCT FEATURES

- > 1103 gravity rollers are having precision bearings with steel bearing housing.
- > Steel bearings housing can stand against greater axial force compared to polymer bearing housing
- > Conveline make Precision ball bearings
- > Temperature range: -20° C to + 80° C
- > High load carrying capacity
- > Bearing Housing – Steel, Zinc plated

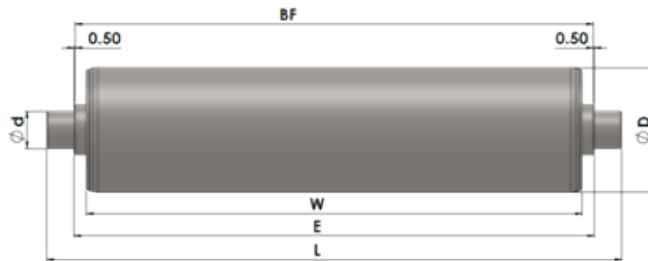

### 1103 Series – Spring Loaded

Tube Dia. (D)	Shaft Dia. (d)			
$\phi 50$	$\phi 15$	$E = W+9$	$BF = W+10$	$L = W+30$
$\phi 76$	$\phi 20$	$E = W+9$	$BF = W+10$	$L = W+30$
$\phi 89$	$\phi 20$	$E = W+9$	$BF = W+10$	$L = W+30$

Tube	D*T	Shaft Dia.	
		$\phi 15$	$\phi 20$
Steel, Zinc plated	50x1.5	1103-SHN-AKS	
	76x3.0		1103-SPN-ALS
	89x3.0		1103-SQN-ALS
Steel, Zinc plated with PVC sleeve	50x1.5	1103-SRS-AKS	
Stainless Steel (SS304)	50x1.5	1103-KHN-BKS	
	76x3.0		1103-KPN-BLS
Aluminium	50x1.5	1103-AHN-AKS	

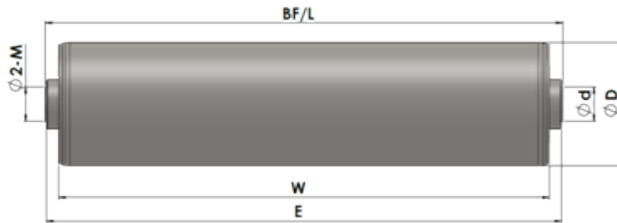

### 1103 Series – Internal Thread

Tube Dia. (D)	Shaft Dia. (d)			
ø50	ø15	E = W+9	BF = W+10	L = W+10
ø76	ø20	E = W+9	BF = W+10	L = W+10
ø89	ø20	E = W+9	BF = W+10	L = W+10

Tube	D*T	Shaft Dia.	
		ø15 (M10x20)	ø20 (M12x20)
Steel, Zinc plated	50x1.5	1103-SHN-AKI	
	76x3.0		1103-SPN-ALI
	89x3.0		1103-SQN-ALI
Steel, Zinc plated with PVC sleeve	50x1.5	1103-SHS-AKI	
Stainless Steel (SS304)	50x1.5	1103-KHN-BKI	
	76x3.0		1103-KPN-BLI
Aluminium	50x1.5	1103-AHN-AKI	

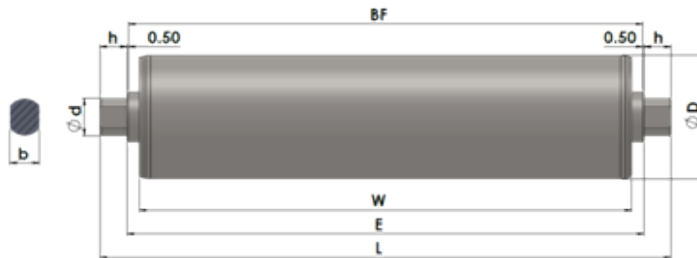

### 1103 Series – Milled Shaft

Tube Dia. (D)	Shaft Dia. (d)			
ø50	ø15	E = W+9	BF = W+10	L = W+40
ø76	ø20	E = W+9	BF = W+10	L = W+40
ø89	ø20	E = W+9	BF = W+10	L = W+40

Tube	D*T	Shaft Dia.	
		ø15 (b/h = 12/11)	ø20 (b/h = 16/15)
Steel, Zinc plated	50x1.5	1103-SHN-AKM	
	76x3.0		1103-SPN-ALM
	89x3.0		1103-SQN-ALM
Steel, Zinc plated with PVC sleeve	50x1.5	1103-SRS-AKM	
Stainless Steel (SS304)	50x1.5	1103-KHN-BKM	
	76x3.0		1103-KPN-BLM
Aluminium	50x1.5	1103-AHN-AKM	

## 1103 Series – Load Capacity

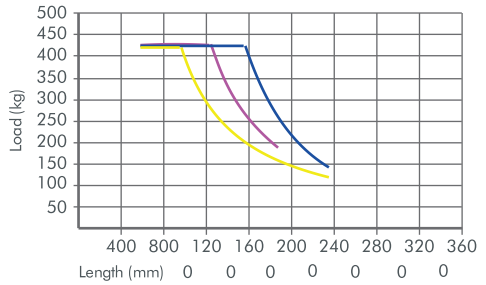
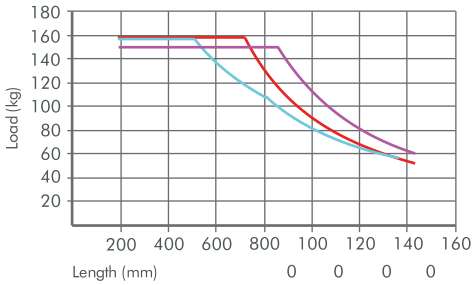

- Steel tube Ø50x1.5, Shaft Ø14, internal thread
- Steel tube Ø50x1.5, Shaft Ø14, spring loaded
- Steel tube Ø50x1.5, Shaft Ø14, milled finish

- Steel tube Ø76x3.0, Shaft Ø20, spring loaded
- Steel tube Ø76x3.0, Shaft Ø20, internal thread
- Steel tube Ø76x3.0, Shaft Ø20, milled finish

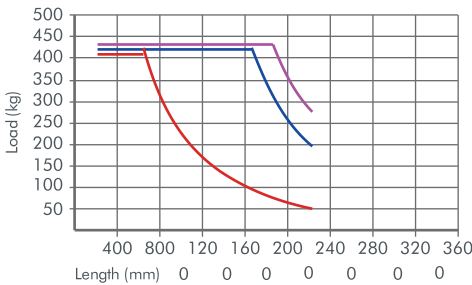

- Steel tube Ø89x3.0, Shaft Ø20, spring loaded
- Steel tube Ø89x3.0, Shaft Ø20, internal thread
- Steel tube Ø89x3.0, Shaft Ø20, milled finish

\* Above data shows the static load capacity of the roller for a uniformly distributed load.



## POWERED ROLLERS

Series	Product Features	Diameter Range
1201 / 1202	○ belt rollers, single or double groove light/ medium duty conveyor rollers, custom made groove	50
1203	○ belt pulley rollers, light/medium duty conveyor rollers	50
1204	Poly V belt pulley rollers, medium duty and high-speed conveyor rollers	50
1205	Timing belt pulley rollers, medium duty and high-speed conveyor rollers	50
1206 / 1207	Polymer sprocket rollers, single or double sprocket, medium duty and low running noise, polyamide bearing housing	50
1208 / 1209	Steel sprocket, single or double sprocket, medium/heavy duty conveying application, polyamide bearing housing	50, 60, 76, 89
1210 / 1211	Steel sprocket, steel bearing housing, heavy duty conveying, strong and reliable	50, 76, 89

## 1201 / 1202 Series

### O-RING POWERED CONVEYOR ROLLERS

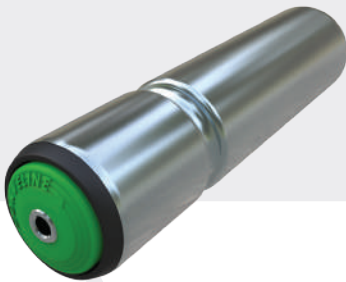

**1201 Series –  
Single Groove Rollers**



**1202 Series –  
Double Groove Rollers**

#### PRODUCT FEATURES

- > 1201 series single groove and 1202 series double groove rollers
- > Mostly used in light and medium duty carton handling application
- > Low noise and safety during running is the main feature of O ring rollers
- > Polymer bearing housing with precision ball bearing
- > Customized groove position
- > Temperature range: -5° C to + 50° C
- > Bearing Housing – Polyamide black
- > End Housing - Green

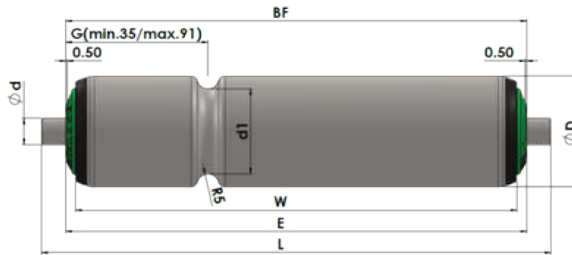

### 1201 Series – Spring loaded

Tube Dia. (D)	Shaft Dia. (d)					
ø50	ø12/11hex/ø14	E = W+10	BF = W+11	L = W+31	G = 65	d1 = 39.5
Tube	D*T	Shaft Dia.				
		11 HEX	ø12	ø14		
Steel, Zinc plated	50x1.5	1201-SHN-AFS	1201-SHN-ABS	1201-SHN-AJS		
	50x2.0			1201-SWN-AJS		
Steel, Zinc plated with PVC sleeve	50x1.5	1201-SRS-AFS	1201-SRS-ABS	1201-SRS-AJS		
Stainless Steel (SS304)	50x1.5	1201-KHN-BFS	1201-KHN-BBS	1201-KHN-BJS		
	50x2.0			1201-KWN-BJS		

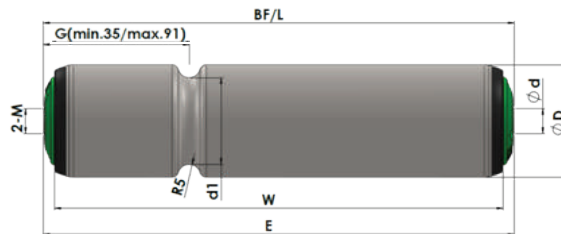

### 1201 Series – Internal Thread

Tube Dia. (D)	Shaft Dia. (d)					
ø50	ø12/ø14	E = W+10	BF = W+11	L = W+11	G = 65	d1 = 39.5
Tube	D*T	Shaft Dia.				
		ø12 (M8x20)	ø14 (M8x20)			
Steel, Zinc plated	50x1.5	1201-SHN-ABI	1201-SHN-ABI			
	50x2.0		1201-SWN-AJI			
Steel, Zinc plated with PVC sleeve	50x1.5	1201-SRS-ABI	1201-SRS-AJI			
Stainless Steel (SS304)	50x1.5	1201-KHN-BBI	1201-KHN-BJI			
	50x2.0		1201-KWN-BJI			



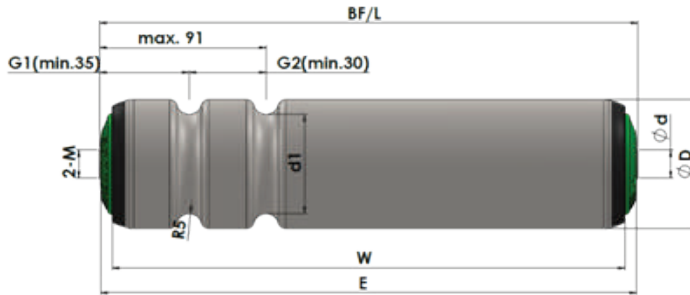

## 1202 Series – Internal Thread

Tube Dia. (D)	Shaft Dia. (d)						
ø50	ø12/ø14	E = W+10	BF = W+11	L = W+11	G1 = 35	G2 = 30	d1 = 39.5

Tube	D*T	Shaft Dia.	
		ø12 (M8x20)	ø14 (M8x20)
Steel, Zinc plated	50x1.5	1202-SHN-ABI	1202-SHN-AJI
	50x2.0		1202-SWN-AJI
Steel, Zinc plated with PVC sleeve	50x1.5	1202-SRS-ABI	1202-SRS-AJI
Stainless Steel (SS304)	50x1.5	1202-KHN-BBI	1202-KHN-BJI
	50x2.0		1202-KWN-BJI

## 1203 Series

### O-RING POWERED CONVEYOR ROLLERS



#### PRODUCT FEATURES

- > Polymer o belt pully separates the drive area and conveying area
- > Mostly used in light and medium duty carton handling application
- > Low noise and safety during running are the main features of O ring rollers
- > Polymer bearing housing with precision ball bearing
- > Temperature range: -5° C to + 50° C
- > Bearing Housing – Polyamide, black
- > O belt pulley – Polyamide, black
- > End Housing – Green

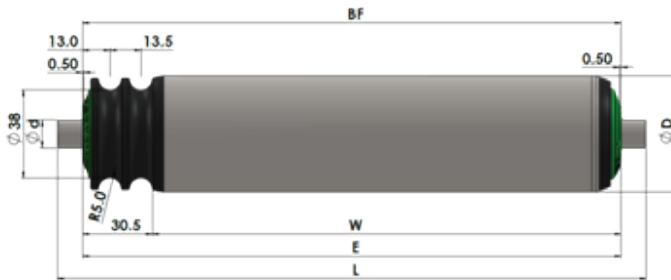

### 1203 Series – Spring loaded

Tube Dia. (D)	Shaft Dia. (d)			
ø50	ø14	E = W+35	BF = W+36	L = W+56

Tube	D*T	Shaft Dia.	
		ø14	11 Hex
Steel, Zinc plated	50x1.5	1203-SHN-AJS	1203-SHN-AFS
Steel, Zinc plated with PVC sleeve	50x1.5	1203-SRS-AJS	1203-SRS-AFS
Stainless Steel (SS304)	50x1.5	1203-KHN-BJS	1203-KHN-BFS
Aluminium	50x1.5	1203-AHN-AJS	1203-AHN-AFS

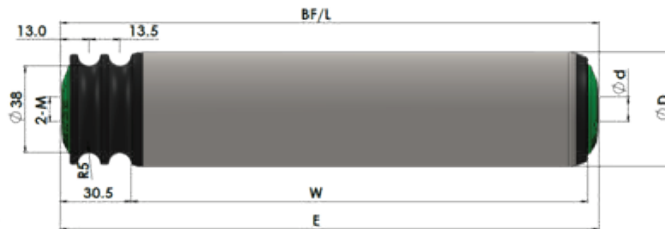

### 1203 Series – Internal Thread

Tube Dia. (D)	Shaft Dia. (d)			
ø50	ø14	E = W+35	BF = W+36	L = W+36

Tube	D*T	Shaft Dia.
		ø14 (M8x20)
Steel, Zinc plated	50x1.5	1203-SHN-AJI
Steel, Zinc plated with PVC sleeve	50x1.5	1203-SRS-AJI
Stainless Steel (SS304)	50x1.5	1203-KHN-BJI
Aluminium	50x1.5	1203-AHN-AJI

## 1204 Series

### POLY VEE POWERED CONVEYOR ROLLERS



#### PRODUCT FEATURES

- > Polymer poly vee belt pulley separates the drive area and conveying area
- > ISO 9982 PJ series poly vee pulley, Total 9 grooves at pitch of 2.34mm
- > Mostly used in light and medium duty carton handling application
- > Suitable for high-speed application up to 120m/min
- > Polymer bearing housing with precision ball bearing
- > Temperature range: -5° C to + 50° C
- > Bearing Housing – Polyamide, black
- > Drive element – Polyamide, black
- > End Housing – Green

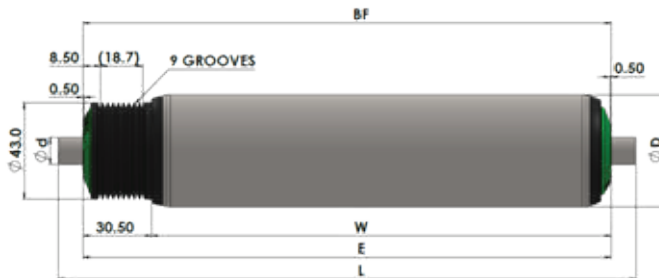

### 1204 Series – Spring Loaded

Tube Dia. (D)	Shaft Dia. (d)			
ø50	ø14	$E = W + 35$	$BF = W + 36$	$L = W + 56$

Tube	D*T	Shaft Dia.	
		ø14	11 Hex
Steel, Zinc plated	50x1.5	1204-SHN-AJS	1204-SHN-AFS
Steel, Zinc plated with PVC sleeve	50x1.5	1204-SRS-AJS	1204-SRS-AFS
Stainless Steel (SS304)	50x1.5	1204-KHN-BJS	1204-KHN-BFS
Aluminium	50x1.5	1204-AHN-AJS	1204-AHN-AFS

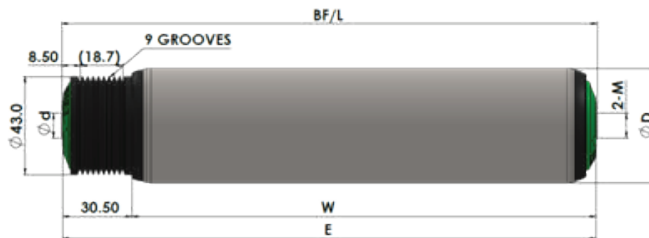

### 1204 Series – Internal Thread

Tube Dia. (D)	Shaft Dia. (d)			
ø50	ø14	$E = W + 35$	$BF = W + 36$	$L = W + 36$

Tube	D*T	Shaft Dia.
		ø14 (M8x20)
Steel, Zinc plated	50x1.5	1204-SHN-AJI
Steel, Zinc plated with PVC sleeve	50x1.5	1204-SRS-AJI
Stainless Steel (SS304)	50x1.5	1204-KHN-BJI
Aluminium	50x1.5	1204-AHN-AJI

## 1205 Series

### TIMING BELT POWERED CONVEYOR ROLLERS

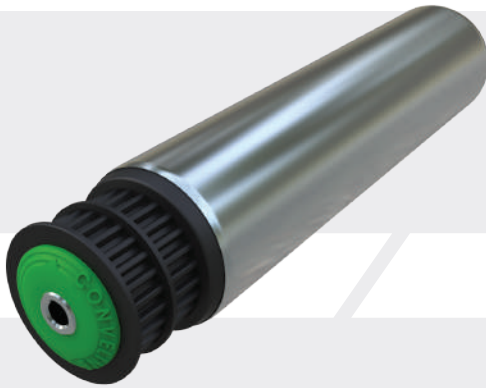

#### PRODUCT FEATURES

- > Polymer timing belt pulley separates the drive area and conveying area
- > Bigger conveying capacity, suitable for medium duty and high speed
- > Mostly used in light and medium duty carton handling application
- > Timing belt width: 10mm
- > No belt tensioning required
- > Precise positioning can be achieved
- > High speed up to 120 m/min
- > No lubrication needed and easy maintenance
- > Polymer bearing housing with precision ball bearing
- > Temperature range: -5° C to + 50° C
- > Bearing Housing – Polyamide, black
- > Drive element – Polyamide, Black
- > End Housing – Green

## 1205 Series – Roller Pitch

- > The center pitch of timing belt is strictly limited as per following.
- > Common pitch and timing belt width shown in table
- > Belt width: 10mm

Center distance (mm)	Type of timing belt	Teeth number of timing belt
60	10-T5-250	50
75	10-T5-280	56
85	10-T5-300	60
100	10-T5-330	66
105	10-T5-340	68
135	10-T5-400	80
145	10-T5-420	84
160	10-T5-450	90

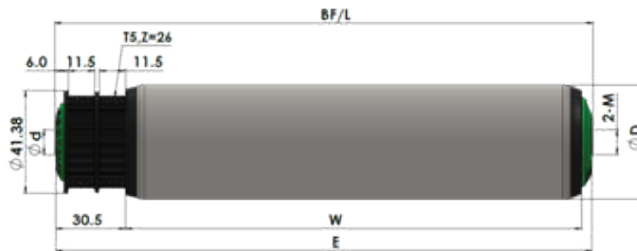

## 1205 Series – Internal Thread

Tube Dia. (D)	Shaft Dia. (d)			
ø50	ø14	E = W+35	BF = W+36	L = W+36

Tube	D*T	Shaft Dia.
		ø14 (M8x20)
Steel, Zinc plated	50x1.5	1205-SHN-AJI
Steel, Zinc plated with PVC sleeve	50x1.5	1205-SRS-AJI
Stainless Steel (SS304)	50x1.5	1205-KHN-BJI
Aluminium	50x1.5	1205-AHN-AJI

## 1206 / 1207 Series

### POWERED CONVEYOR ROLLERS



**1206 Series –  
Single Sprocket Rollers**



**1207 Series –  
Double Sprocket Rollers**

#### PRODUCT FEATURES

- > 1206/1207 series polyamide single/double sprocket rollers
- > Low noise during running is the main feature of polyamide sprocket rollers
- > Suitable for light and medium duty application
- > Polymer bearing housing with precision ball bearing
- > 1206 Suitable for low/medium speed application
- > 1207 suitable for medium and heavy-duty application
- > Double sprocket speed is higher up to 30m/min
- > Temperature range: -5° C to + 50° C
- > Bearing Housing – Polyamide black
- > End Housing – Green

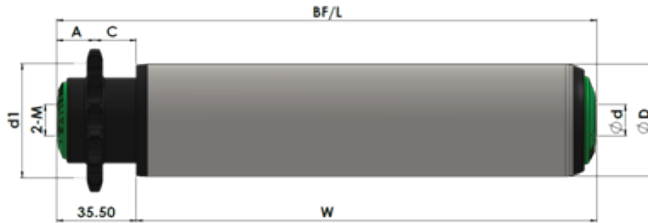

### 1206 Series – Internal Thread

Tube Dia. (D)	Shaft Dia. (d)		Sprocket Style	A	C	d1
ø50	ø14	$BF/L = W + 38.5$	08B14T	15	18	$d1 = 38.5$

Tube	D*T	Shaft Dia.
		ø14 (M8x20)
Steel, Zinc plated	50x1.5	1206-SHN-AJI
Steel, Zinc plated with PVC sleeve	50x1.5	1206-SRS-AJI
Stainless Steel (SS304)	50x1.5	1206-KHN-BJI
Aluminium	50x1.5	1206-AHN-AJI

### Single Chain Sprocket Drive

- > The compact design is suitable for medium/low speed and continuous operation.
- > Typically, conveyor design consider with a chain tensioner.

### Single Chain Layout

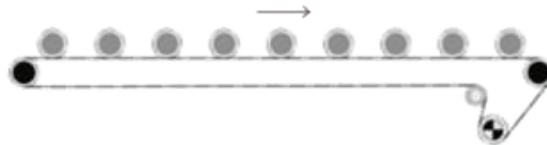

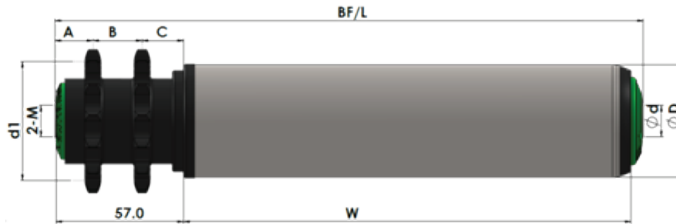

### 1207 Series – Internal Thread

Tube Dia. (D)	Shaft Dia. (d)		Sprocket Style	A	B	C	d1
ø50	ø14	BF/L = W+62	08B14T	15.5	22	18.5	d1=57.07

Tube	D*T	Shaft Dia.
		ø14 (M8x20)
Steel, Zinc plated	50x1.5	1207-SHN-AJI
Steel, Zinc plated with PVC sleeve	50x1.5	1207-SRS-AJI
Stainless Steel (SS304)	50x1.5	1207-KHN-BJI
Aluminium	50x1.5	1207-AHN-AJI

### Pitch Selection

Type	Pitch	Center Distance (T)					Tolerance
08B11T	12.7	69.8	82.5	82.5	82.5	82.5	82.5
08B14T	12.7	88.9	101.6	101.6	101.6	101.6	101.6
10A13T	15.875	119	134.9	134.9	134.9	134.9	134.9
10B15T	15.875	134.9	150.8	150.8	150.8	150.8	150.8

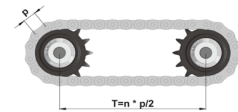

p = Chain pitch  
n = integer 1,2,3...  
Roller pitch T = n\*p/2

### Double Chain layout



## 1208 / 1209 Series

### POWERED CONVEYOR ROLLERS

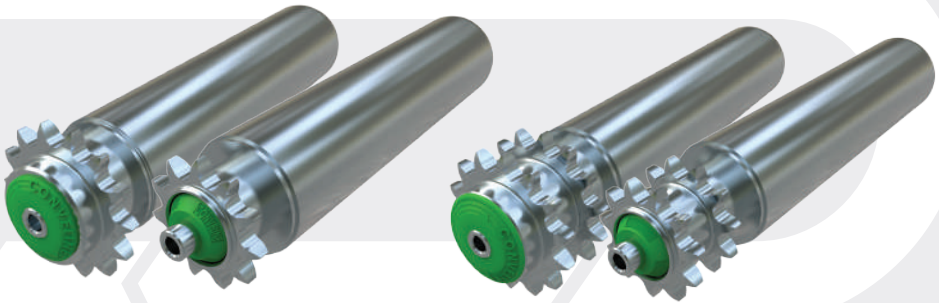

**1208 Series –  
Steel Single Sprocket Rollers**

**1209 Series –  
Steel Double Sprocket Rollers**

#### PRODUCT FEATURES

- > 1208/1209 series steel single/double sprocket rollers
- > Welded steel sprocket gives it higher load carrying capacity with higher torque
- > Suitable for medium and heavy-duty application
- > Polymer bearing housing with precision ball bearing
- > 1208 Suitable for low/medium speed application
- > 1209 suitable for medium and heavy-duty application
- > Double sprocket speed is higher up to 30m/min
- > Temperature range: -5° C to + 50° C
- > Bearing Housing – Polyamide black
- > End Housing– Green

## 1208/1209 Series Conveyor Rollers

### Load Capacity

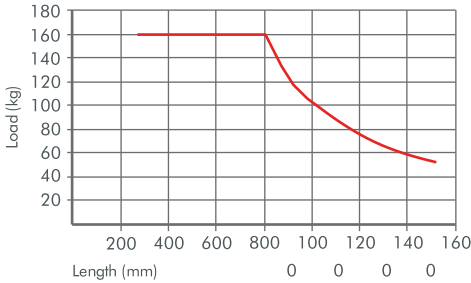

- Steel tube Ø50x1.5, Shaft Ø12/14/15, internal thread

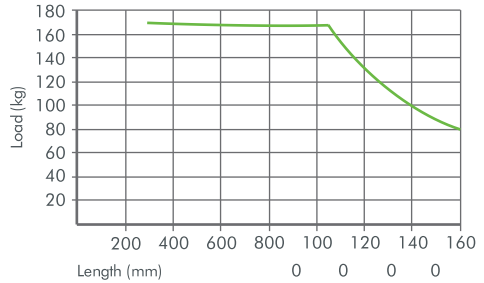

- Steel tube Ø60x2.0, Shaft Ø12/15, internal thread

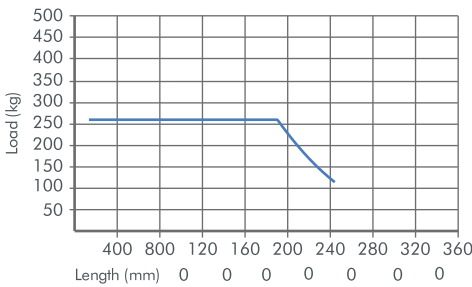

- Steel tube Ø76x3.0, Shaft Ø20, internal thread

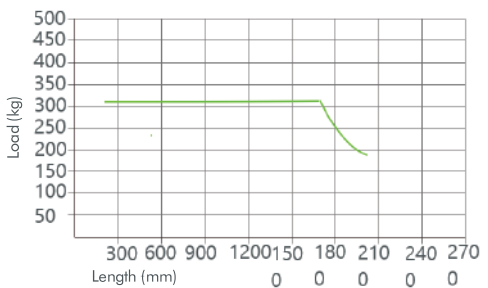

- Steel tube Ø89x3.0, Shaft Ø20, internal thread

\* Above data shows the static load capacity of the roller for a uniformly distributed load.

### Pitch Selection

Type	Pitch	Center Distance (T)					Tolerance
08B11T	12.7	69.8	82.5	95.2	107.9	120.6	0/-0.4
08B14T	12.7	88.9	101.6	114.3	127	139.7	0/-0.4
10A13T	15.875	119	134.9	150.8	166.6	182.5	0/-0.7
10B15T	15.875	134.9	150.8	166.6	182.5	198.4	0/-0.7

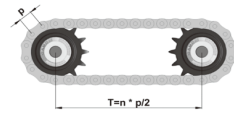

$p$  = Chain pitch  
 $n$  = integer 1,2,3...  
 Roller pitch  $T = n * p / 2$

### Double Chain layout



### Single Chain Layout

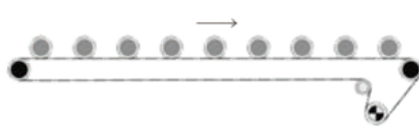

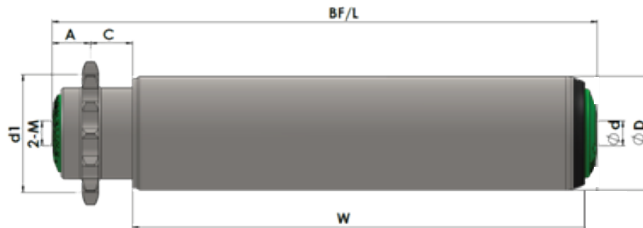

### 1208 Series – Internal Thread

Tube Dia. (D)	Shaft Dia. (d)		Sprocket Style	A	C	d1
ø50	ø14	BF/L = W+41	08B14T	17	18.5	d1 = 57.07
ø60	ø15	BF/L = W+41	08B14T	17	18.5	d1 = 57.07
ø76	ø20	BF/L = W+37	10B15T	18	13	d1 = 76.35
ø89	ø20	BF/L = W+37	10B15T	18	13	d1 = 76.35

Tube	D*T	Shaft Dia.		
		ø14 (M8x20)	ø15 (M10x20)	ø20 (M12x20)
Steel, Zinc plated	50x1.5	1208-SHN-AJI		
	50x2.0	1208-SWN-AJI		
	60x2.0		1208-SON-AKI	
	76x3.0			1208-SPN-ALI
	89x3.0			1208-SQN-ALI
Steel, Zinc plated with PVC sleeve	50x1.5	1208-SRS-AJI		
Stainless Steel (SS304)	50x1.5	1208-KHN-BJI		
	50x2.0	1208-KWN-BJI		
	60x2.0		1208-KON-BKI	
	76x3.0			1208-KPN-BLI
Steel zinc plated with steel flange	76x3.0			1208-SPF-ALI
	89x3.0			1208-SQF-ALI

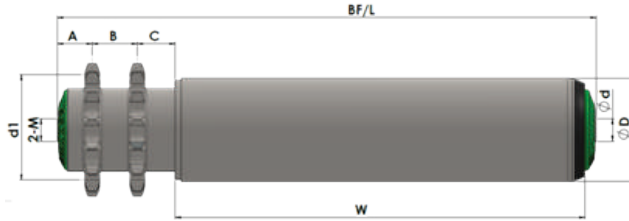

### 1209 Series – Internal Thread

Tube Dia. (D)	Shaft Dia. (d)		Sprocket Style	A	B	C	d1
ø50	ø14	BF/L = W+63	08B14T	17	22	18.5	d1 = 57.07
ø60	ø15	BF/L = W+63	08B14T	17	22	18.5	d1 = 57.07
ø76	ø20	BF/L = W+63	10B15T	18	26	13	d1 = 76.35
ø89	ø20	BF/L = W+63	10B15T	18	26	13	d1 = 76.35

Tube	D*T	Shaft Dia.		
		ø14 (M8x20)	ø15 (M10x20)	ø20 (M12x20)
Steel, Zinc plated	50x1.5	1209-SHN-AJI		
	50x2.0	1209-SWN-AJI		
	60x2.0		1209-SON-AKI	
	76x3.0			1209-SPN-ALI
	89x3.0			1209-SQN-ALI
Steel, Zinc plated with PVC sleeve	50x1.5	1209-SRS-AJI		
Stainless Steel (SS304)	50x1.5	1209-KHN-BJI		
	50x2.0	1209-KWN-BJI		
	60x2.0		1209-KON-BKI	
	76x3.0			1209-KPN-BLI
Steel zinc plated with steel flange	76x3.0			1209-SPF-ALI
	89x3.0			1209-SQF-ALI

## 1210 / 1211 Series

### POWERED CONVEYOR ROLLERS WITH STEEL HOUSING

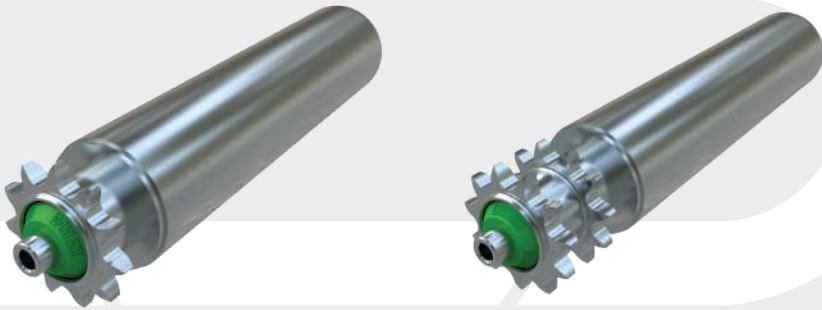

**1210 Series – Steel Single  
Sprocket with Steel housing Rollers**

**1211 Series – Steel Double  
Sprocket with Steel housing Rollers**

#### PRODUCT FEATURES

- > 1210 series steel single sprocket rollers and 1211 series steel double sprocket rollers
- > Welded steel sprocket gives it higher load carrying capacity with higher torque
- > Suitable for high load application
- > Temperature range: -20° C to + 80° C
- > Steel bearing housing with precision ball bearing
- > Bearing Housing – steel, zinc plated
- > End housing Green

## Pitch Selection

Type	Pitch	Center Distance (T)					Tolerance
08B11T	12.7	69.8	82.5	95.2	107.9	120.6	0/-0.4
08B14T	12.7	88.9	101.6	114.3	127	139.7	0/-0.4
10A13T	15.875	119	134.9	150.8	166.6	182.5	0/-0.7
10B15T	15.875	134.9	150.8	166.6	182.5	198.4	0/-0.7

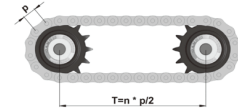

$p$  = Chain pitch  
 $n$  = integer 1,2,3...  
 Roller pitch  $T = n * p / 2$

## Load Capacity

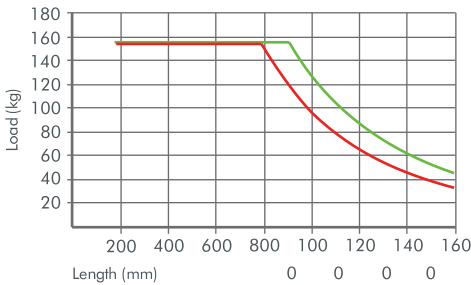

- Steel tube Ø50x1.5, Shaft Ø14, internal thread
- Steel tube Ø50x2.0, Shaft Ø14, internal thread

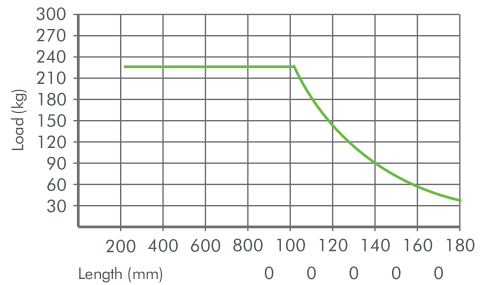

- Steel tube Ø60x2.0, Shaft Ø15, internal thread

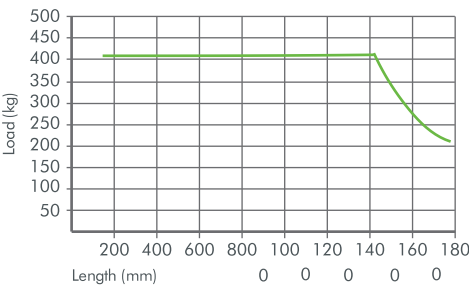

- Steel tube Ø76x3.0, Shaft Ø20, internal thread

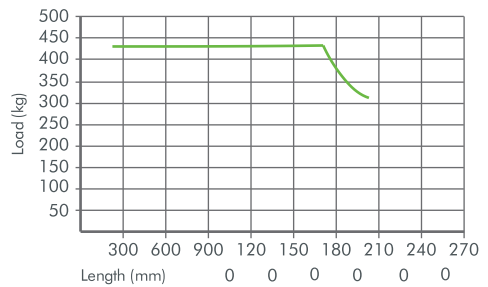

- Steel tube Ø89x3.0, Shaft Ø20, internal thread

\* Above data shows the static load capacity of the roller for a uniformly distributed load.

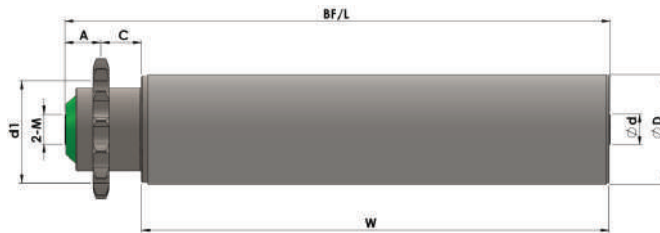

### 1210 Series – Internal Thread

Tube Dia. (D)	Shaft Dia. (d)		Sprocket Style	A	C	d1
ø50	ø14	BF/L = W+41	08B14T	17	18.5	d1 = 57.07
ø76	ø20	BF/L = W+44	10B15T	20	18.5	d1 = 76.35
ø89	ø20	BF/L = W+44	10B15T	20	18.5	d1 = 76.35

Tube	D*T	Shaft Dia.	
		ø14 (M8x20)	ø20 (M12x20)
Steel, Zinc plated	50x1.5	1210-SHN-AJI	
	50x2.0	1210-SWN-AJI	
	76x3.0		1210-SPN-ALI
	89x3.0		1210-SQN-ALI
Steel, Zinc plated with PVC sleeve	50x1.5	1210-SRS-AJI	
Stainless Steel (SS304)	50x1.5	1202-KHN-BJI	
	50x2.0	1202-KWN-BJI	
	76x3.0		1210-KPN-BLI
Steel zinc plated with steel flange	76x3.0		1210-SPF-ALI
	89x3.0		1210-SQF-ALI

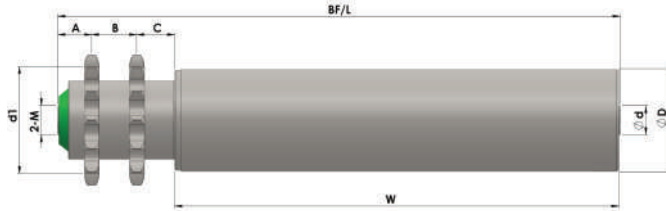

### 1211 Series – Internal Thread

Tube Dia. (D)	Shaft Dia. (d)		Sprocket Style	A	B	C	d1
ø50	ø14	BF/L = W+63	08B14T	17	22	18.5	d1 = 57.07
ø76	ø20	BF/L = W+63	10B15T	18	28	13	d1 = 76.35
ø89	ø20	BF/L = W+63	10B15T	18	28	13	d1 = 76.35

Tube	D*T	Shaft Dia.	
		ø14 (M8x20)	ø20 (M12x20)
Steel, Zinc plated	50x1.5	1211-SHN-AJI	
	50x2.0	1211-SWN-AJI	
	76x3.0		1211-SPN-ALI
	89x3.0		1211-SQN-ALI
Steel, Zinc plated with PVC sleeve	50x1.5	1211-SRS-AJI	
	50x2.0	1211-KHN-BJI	
Stainless Steel (SS304)	50x2.0	1211-KWN-BJI	
	76x3.0		1211-KPN-BLI
	76x3.0		1211-SPF-ALI
Steel zinc plated with steel flange	76x3.0		1211-SPF-ALI
	89x3.0		1211-SQF-ALI

## POWERED CONVEYOR ROLLERS WITH FLANGE

### Steel flange

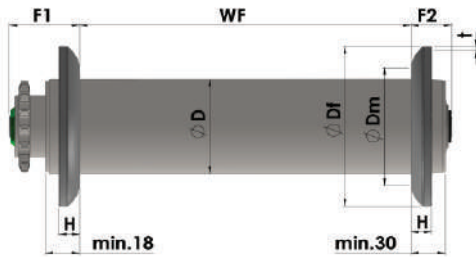

D	Df	Dm	H	t
Ø76	Ø132.5	Ø96.1	11	3
Ø89	Ø150	Ø110	18	4

- > Steel flange and steel tube are welded together for making it stronger and durable

### Stainless Steel (SS304) flange

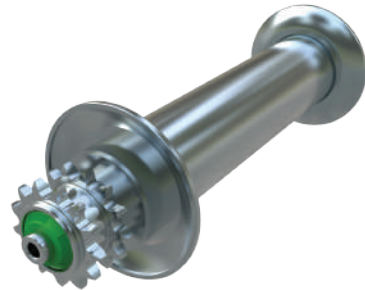
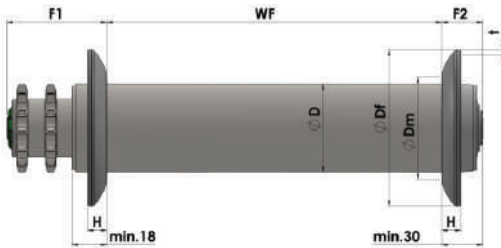

D	Df	Dm	H	t
Ø76	Ø132.5	Ø96.1	11	3

- > Stainless steel flange and stainless steel tube are welded together for making it stronger and durable
- > SS304 flange part code is not mentioned in this catalogue so contact our sales team

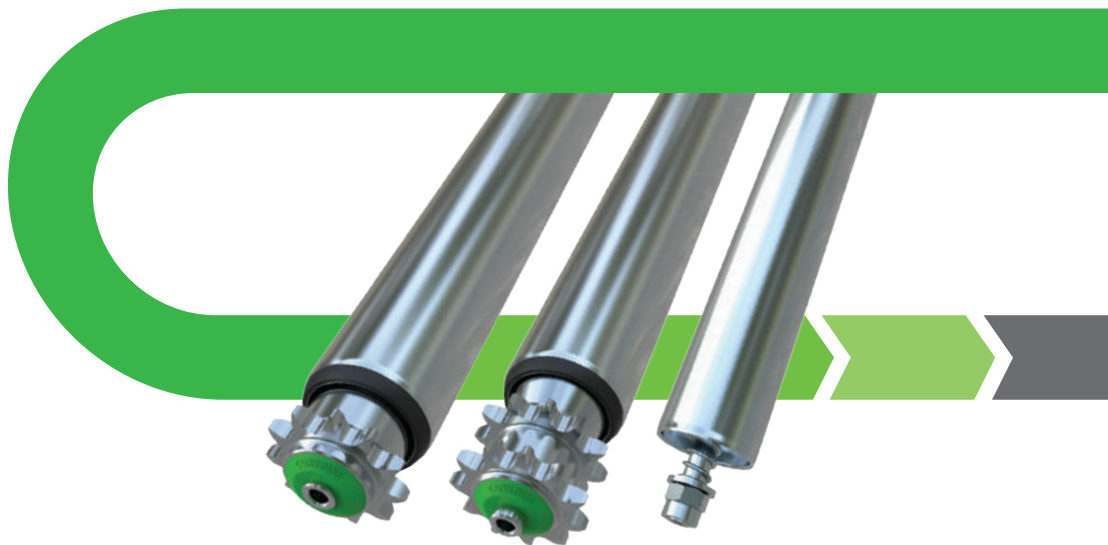

## ACCUMULATION ROLLERS

Series	Product Features	Diameter Range
1301 / 1302	Polymer sprocket rollers, single or double sprocket, low running noise, polyamide bearing housing	50
1303 / 1304	Steel sprocket, single or double sprocket, polyamide bearing housing	50
1305 / 1306	Steel sprocket, adjustable torque, single or double sprocket, polyamide/steel bearing housing	50, 60, 76

## 1301 / 1302 Series

### SINGLE & DOUBLE SPROCKET ACCUMULATION CONVEYOR ROLLERS



**1301 Series –  
Single Sprocket Rollers**



**1302 Series –  
Double Sprocket Rollers**

#### PRODUCT FEATURES

- > 1301/1302 series polyamide Single/Double sprocket rollers
- > With friction driven accumulation, the accumulation force depends on its load
- > Temperature range: -5° C to + 50° C
- > Polymer bearing housing with precision ball bearing
- > Low noise during running is the main feature of polyamide sprocket rollers
- > Bearing Housing – Polyamide black
- > End Housing – Green

#### Polymer Single/Double Sprocket Accumulation Roller

Load Duty Capacity

Conveying Goods material / Roller Materials	Steel Tube	Rubber Lagging
Paper	3~20kg	2~15kg
Plastic	5~25kg	2~20kg

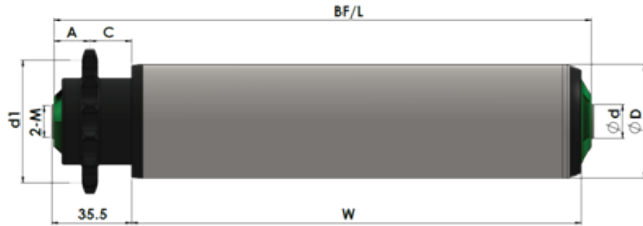

### 1301 Series – Internal Thread

Tube Dia. (D)	Shaft Dia. (d)		Sprocket Style	A	C	d1
ø50	ø14	BF/L = W+38.5	08B14T	15	18	d1 = 57.07

Tube	D*T	Shaft Dia.
		ø14 (M8x20)
Steel, Zinc plated	50x1.5	1301-SHN-AJI
Stainless Steel (SS304)	50x1.5	1301-KHN-BJI

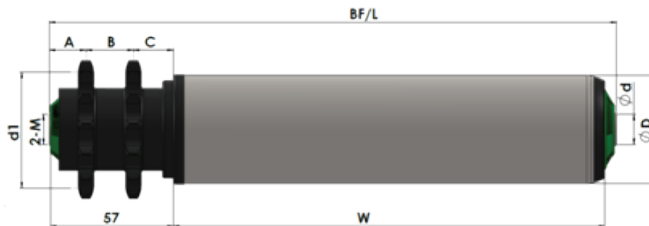

### 1302 Series — Internal Thread

Tube Dia. (D)	Shaft Dia. (d)		Sprocket Style	A	B	C	d1
ø50	ø14	BF/L = W+62	08B14T	15.5	22	18.5	d1 = 57.07

Tube	D*T	Shaft Dia.
		ø14 (M8x20)
Steel, Zinc plated	50x1.5	1302-SHN-AJI
Stainless Steel (SS304)	50x1.5	1302-KHN-BJI

## 1303 / 1304 Series

### ACCUMULATION CONVEYOR ROLLERS

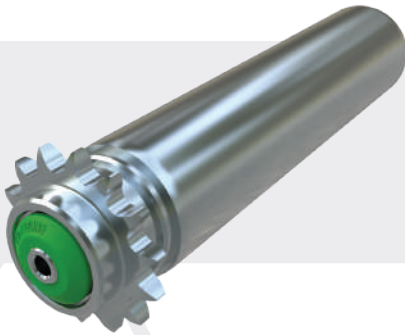

**1303 Series –  
Single Sprocket Rollers**

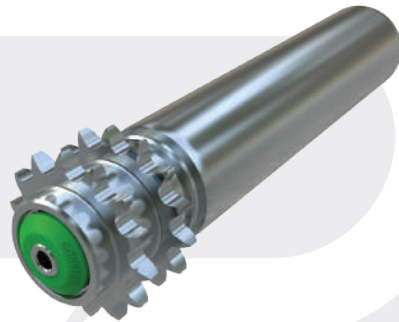

**1304 Series –  
Double Sprocket Rollers**

#### PRODUCT FEATURES

- > 1303/1304 series steel single/double sprocket rollers
- > With friction driven accumulation, the accumulation force depends on its load
- > Temperature range: -5° C to + 50° C
- > Polyamide bearing housing with precision ball bearing
- > Bearing Housing – Polyamide black
- > End Housing – Green

#### Steel Single/Double Sprocket Accumulation Roller

Load Duty Capacity/pc

Conveying Goods material / Roller Materials	Steel Tube	Rubber Lagging
Paper	3~15kg	2~15kg
Plastic	5~20kg	2~15kg

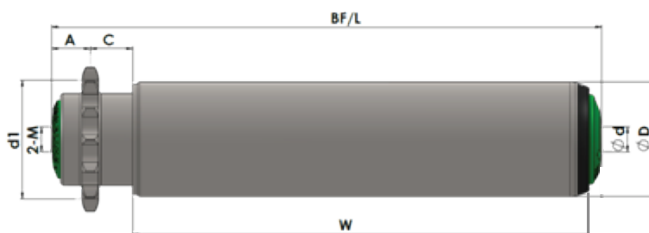

### 1303 Series – Internal Thread

Tube Dia. (D)	Shaft Dia. (d)		Sprocket Style	A	C	d1
ø50	ø14	$BF/L = W + 41$	08B14T	17	18.5	57.07

Tube	D*T	Shaft Dia.
		ø14 (M8x20)
Steel, Zinc plated	50x1.5	1303-SHN-ABI
Stainless Steel (SS304)	50x1.5	1303-KHN-BBI

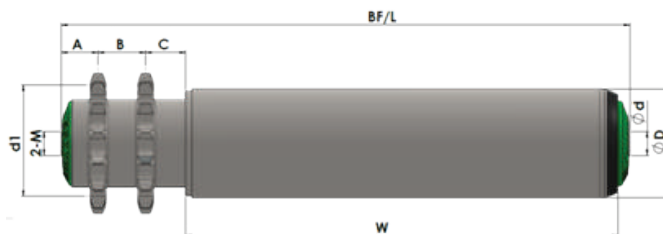

### 1304 Series – Internal Thread

Tube Dia. (D)	Shaft Dia. (d)		Sprocket Style	A	B	C	d1
ø50	ø14	$BF/L = W + 63$	08B14T	17	22	18.5	$d1 = 57.07$

Tube	D*T	Shaft Dia.
		ø14 (M8x20)
Steel, Zinc plated	50x1.5	1304-SHN-AJI
Stainless Steel (SS304)	50x1.5	1304-KHN-BJI

## 1305 / 1306 Series

### ACCUMULATION CONVEYOR ROLLERS



**1305 series –  
Single sprocket rollers**

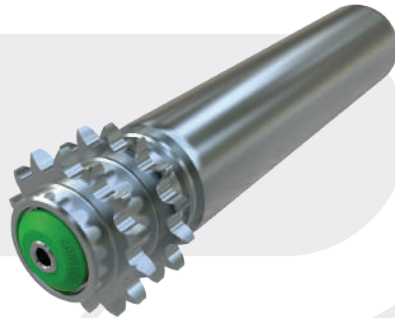

**1306 series –  
Double sprocket rollers**

#### PRODUCT FEATURES

- > 1305/1306 series steel single/double sprocket adjustable rollers
- > Accumulation force can be adjusted by the nut at the end of the roller
- > Temperature range: -5° C to +50° C
- > Polyamide/steel bearing housing with precision ball bearing
- > Bearing Housing – Polyamide/Steel
- > End Housing – Green

#### Steel Single/Double Sprocket Accumulation Roller

Load Duty Capacity/pc

Conveying Goods material / Roller Materials	Ø50x1.5	Ø60x2.0	Ø76x3.0
Plastic	0~55kg	0~70kg	0~120kg
Wood			
Paper	0~40kg		

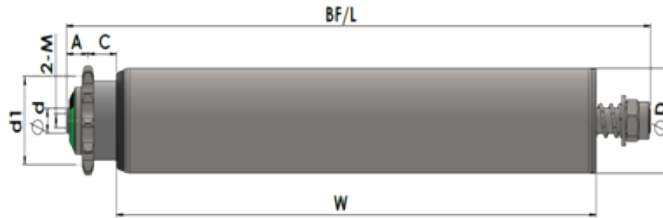

### 1305 Series – Internal Thread

Tube Dia. (D)	Shaft Dia. (d)		Sprocket Style	A	C	d1
ø50	ø14	BF/L = W+70	08B14T	17	18.5	57.07
ø60	ø15	BF/L = W+70	08B14T	17	18.5	57.07
ø76	ø20	BF/L = W+78	10B15T	20	18.5	66.33

Tube	D*T	Shaft Dia.		
		ø15 (M8x20)	ø15 (M10x15)	ø20 (M12x20)
Steel, Zinc plated	50x1.5	1305-SHN-AJI		
	60x2.0		1305-SON-AKI	
	76x3.0			1305-SPN-ALI
Stainless Steel (SS304)	50x1.5	1305-KHN-BJI		
	60x2.0		1305-KON-BKI	
	76x3.0			1209-SON-AKI

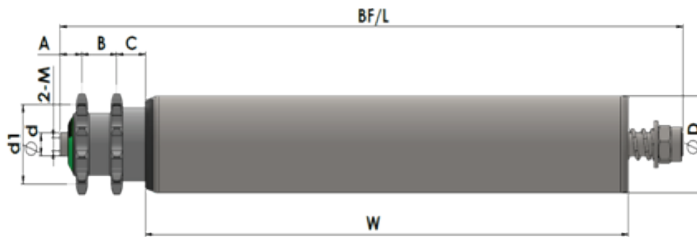

### 1306 Series – Internal Thread

Tube Dia. (D)	Shaft Dia. (d)		Sprocket Style	A	B	C	d1
ø50	ø14	BF/L = W+92	08B14T	17	22	18.5	d1 = 57.07
ø60	ø15	BF/L = W+92	08B14T	17	22	18.5	d1 = 57.07
ø76	ø20	BF/L = W+103	10B15T	20	25	18.5	d1 = 66.33

Tube	D*T	Shaft Dia.		
		ø15 (M8x20)	ø15 (M10x15)	ø20 (M12x20)
Steel, Zinc plated	50x1.5	1306-SHN-AJI		
	60x2.0		1306-SON-AKI	
	76x3.0			1306-SPN-ALI
Stainless Steel (SS304)	50x1.5	1306-KHN-BJI		
	60x2.0		1306-KON-BKI	
	76x3.0			1306-KPN-BLI

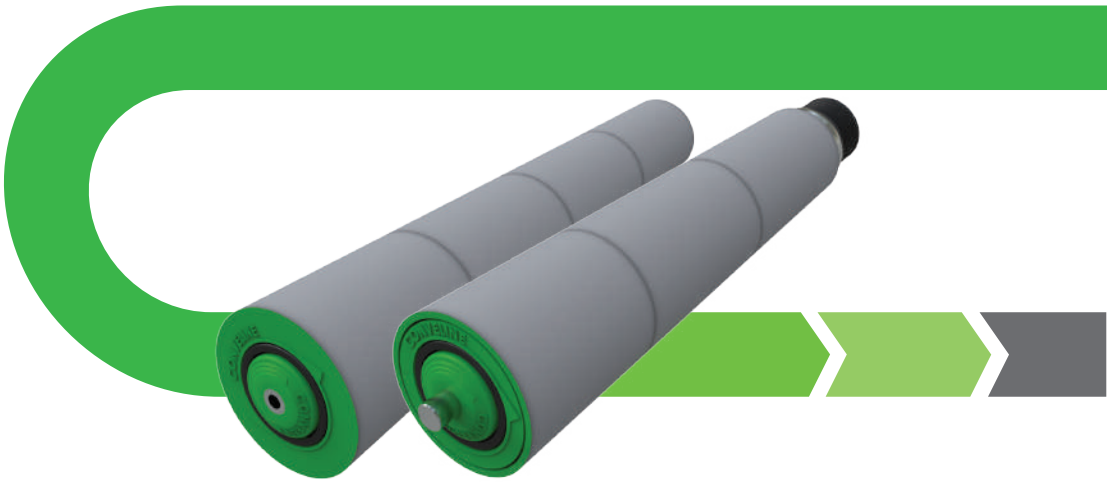

## CURVE ROLLERS

Series	Product Features	Diameter Range
1401	Gravity tapered roller, attractive look and low noise	52.9/56
1402	O belt drive, Double grooved tapered sleeve roller, customized groove position	52.9/56
1403	O belt pulley drive, Double grooved O belt pulley tapered sleeve roller	52.9/56
1404	Poly vee belt pulley drive tapered sleeve roller, high speed, low noise	52.9/56
1405	Polymer sprocket drive tapered sleeve roller, medium duty, low noise	52.9/56

## Curve Conveyor Rollers

### TECHNICAL SELECTION

#### Roller pitch

- > Roller pitch should be selected carefully as it is directly affected to product running performance and conveyor durability, Ideally there are always minimum three rollers to support the product during conveying
- > For Poly v tapered rollers the recommended pitch of poly vee pulleys is 73.7mm

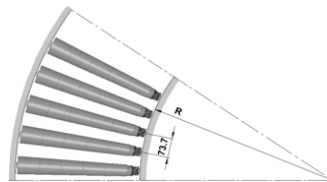
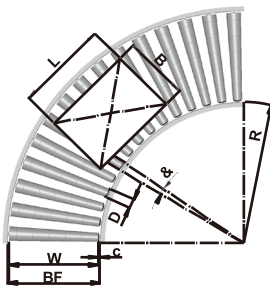

#### Turn radius

Curve inner radius can be calculated with following formula

$$R = \frac{D}{K} - C$$

R = Turning Radius

D = Diameter of smaller side of tapered roller

K = Conical degree (Conical degree is expressed by fraction, e.g. 1/16, 1/30, its reduction formula is  $K = 2 * \tan \theta / 2$ )

C = Space between taper roller smaller end and inner frame

#### Calculation of roller length

For curve conveying, roller length and product width is important factor, which can be calculated as below

$$BF = \sqrt{(R + B)^2 + \left(\frac{L}{2}\right)^2} - R + (\text{min. } 125)$$

BF = Frame inner width

R = Turn inner radius

B = Width of goods

L = Length of goods

After confirming BF, one can calculate roller length W and taper sleeve length WT. The tapered sleeve WT is available in increment of 50mm.

Series	Taper	Small Dia. (D)	Curve Radius (R)
1401/1405	3.6°	52.9	830
		56	880
1403/1404	3.6°	52.9	800
		56	850
1402	3.6°	52.9	760
		56	810

## 1401 Series

### GRAVITY CURVE CONVEYOR ROLLERS

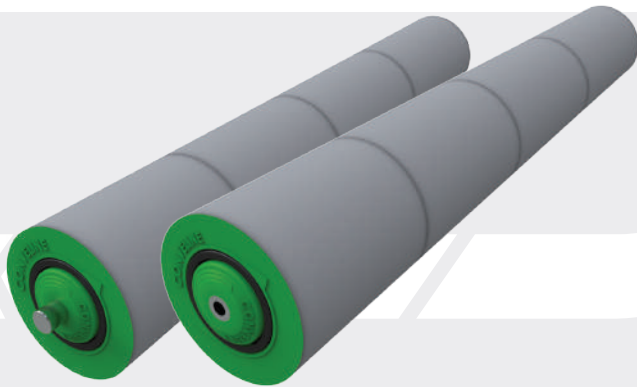

#### PRODUCT FEATURES

- > 1401 series tapered rollers are fitted with grey taper curve sleeve
- > Low noise during running and shockproof is the main features of sleeve rollers
- > Weight of individual item should not go beyond 50 kg
- > Temperature range:  $-5^{\circ}\text{C}$  to  $+50^{\circ}\text{C}$
- > Polyamide bearing housing with precision ball bearing
- > Bearing Housing – Polyamide
- > End Housing – Green

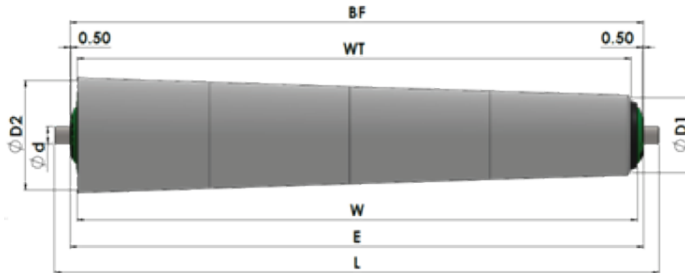

### 1401 Series – Spring Loaded

Tube Dia. (D)	Shaft Dia. (d)			
ø50	ø12/11hex/ø14	E = W+10	BF = W+11	L = W+31

Tube	D*T	WT	D1	D2	Shaft Dia. ø12/ø14	Shaft Dia. ø11 hex
Steel, Zinc plated, tapered sleeve	50x1.5	300	ø56	ø74.9	1401-SHT-ABS / 1401-SHT-AJS	1401-SHT-AFS
		350	ø52.9	ø74.9		
		400	ø56	ø81.1		
		450	ø52.9	ø81.1		
		500	ø56	ø87.4		
		550	ø52.9	ø87.4		
		600	ø56	ø93.7		
		650	ø52.9	ø93.7		
		700	ø56	ø100		
		750	ø52.9	ø100		
		800	ø56	ø106.3		
		850	ø52.9	ø106.3		
		900	ø56	ø112.6		
		950	ø52.9	ø112.6		
		1000	ø56	ø118.9		
		1050	ø52.9	ø118.9		
1100	ø56	ø125.2				
1150	ø52.9	ø125.2				
1200	ø56	ø131.5				

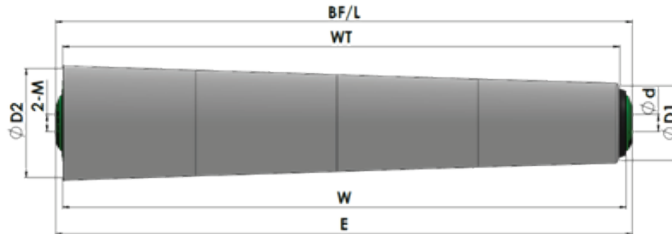

### 1401 Series – Internal Thread

Tube Dia. (D)	Shaft Dia. (d)			
ø50	ø12/ø14	E = W+10	BF = W+10	L = W+11

Tube	D*T	WT	D1	D2	Shaft Dia. ø12 (M8x20)	Shaft Dia. ø14 (M8x20)
Steel, Zinc plated, tapered sleeve	50x1.5	300	ø56	ø74.9	1401-SHT-ABI	1401-SHT-AJI
		350	ø52.9	ø74.9		
		400	ø56	ø81.1		
		450	ø52.9	ø81.1		
		500	ø56	ø87.4		
		550	ø52.9	ø87.4		
		600	ø56	ø93.7		
		650	ø52.9	ø93.7		
		700	ø56	ø100		
		750	ø52.9	ø100		
		800	ø56	ø106.3		
		850	ø52.9	ø106.3		
		900	ø56	ø112.6		
		950	ø52.9	ø112.6		
		1000	ø56	ø118.9		
		1050	ø52.9	ø118.9		
1100	ø56	ø125.2				
1150	ø52.9	ø125.2				
1200	ø56	ø131.5				

## 1402 Series

### DOUBLE GROOVE TAPERED SLEEVE ROLLERS

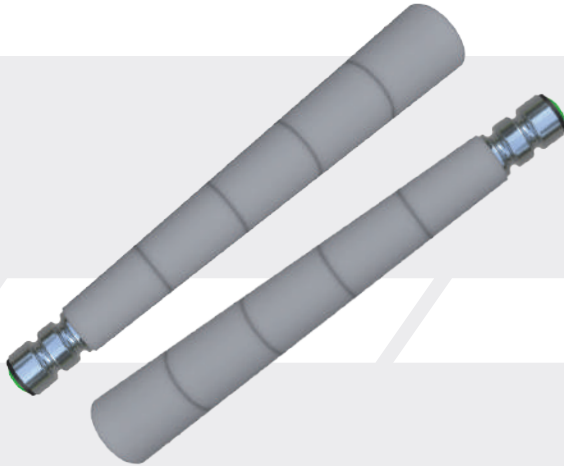

#### PRODUCT FEATURES

- > 1402 series double groove rollers with grey tapered sleeve
- > Low noise and safety during running is the main feature of O ring rollers
- > Polymer bearing housing with precision ball bearing
- > Customized groove position
- > Temperature range: -5° C to + 50° C
- > Bearing Housing – Polyamide black
- > End Housing – Green

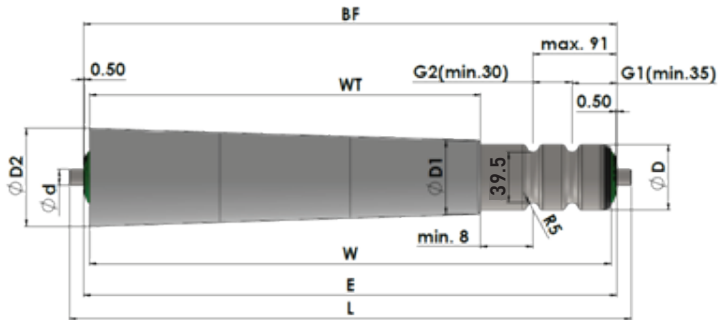

### 1402 Series – Spring Loaded

Tube Dia. (D)	Shaft Dia. (d)				G1	G2
ø50	ø12/11hex/ø14	E = W+10	BF = W+11	L = W+31	35	30

Tube	D*T	WT	D1	D2	Shaft Dia. ø12/ø14	Shaft Dia. ø11 hex
Steel, Zinc plated, tapered sleeve	50x1.5	300	ø56	ø74.9	1402-SHT-ABS / 1402-SHT-AJS	1402-SHT-AFS
		350	ø52.9	ø74.9		
		400	ø56	ø81.1		
		450	ø52.9	ø81.1		
		500	ø56	ø87.4		
		550	ø52.9	ø87.4		
		600	ø56	ø93.7		
		650	ø52.9	ø93.7		
		700	ø56	ø100		
		750	ø52.9	ø100		
		800	ø56	ø106.3		
		850	ø52.9	ø106.3		
		900	ø56	ø112.6		
		950	ø52.9	ø112.6		
		1000	ø56	ø118.9		
1050	ø52.9	ø118.9				
1100	ø56	ø125.2				
1150	ø52.9	ø125.2				
1200	ø56	ø131.5				

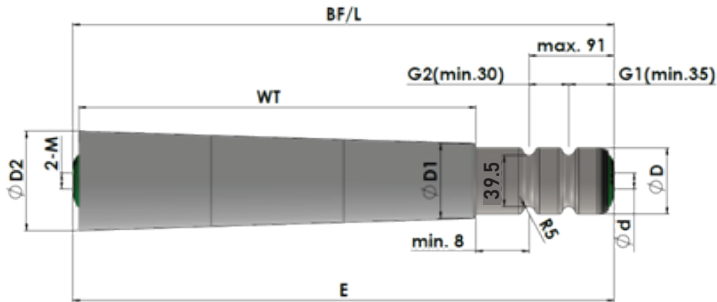

### 1402 Series – Internal Thread

Tube Dia. (D)	Shaft Dia. (d)				G1	G2
ø50	ø12/ø14	E = W+10	BF = W+11	L = W+11	35	30

Tube	D*T	WT	D1	D2	Shaft Dia. ø12 (M8x20)	Shaft Dia. ø14 (M8x20)
Steel, Zinc plated, tapered sleeve	50x1.5	300	ø56	ø74.9	1402-SHT-ABI	1402-SHT-AJI
		350	ø52.9	ø74.9		
		400	ø56	ø81.1		
		450	ø52.9	ø81.1		
		500	ø56	ø87.4		
		550	ø52.9	ø87.4		
		600	ø56	ø93.7		
		650	ø52.9	ø93.7		
		700	ø56	ø100		
		750	ø52.9	ø100		
		800	ø56	ø106.3		
		850	ø52.9	ø106.3		
		900	ø56	ø112.6		
		950	ø52.9	ø112.6		
		1000	ø56	ø118.9		
		1050	ø52.9	ø118.9		
1100	ø56	ø125.2				
1150	ø52.9	ø125.2				
1200	ø56	ø131.5				

## 1403 Series

### ○ BELT PULLEY TAPERED SLEEVE ROLLERS

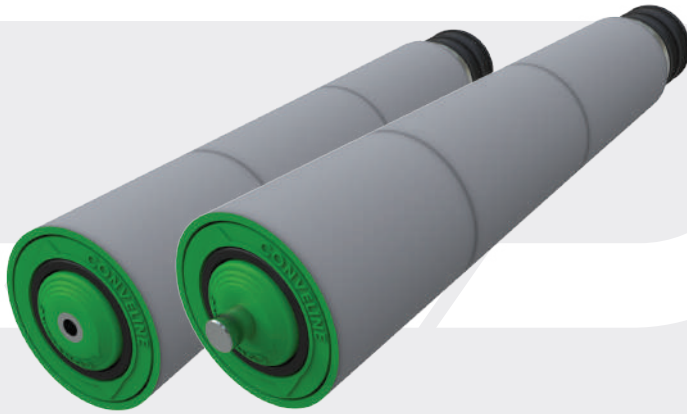

#### PRODUCT FEATURES

- > 1403 series double groove pulley rollers with grey tapered sleeve
- > Polymer o belt pulley separates the drive area and conveying area
- > Low noise and safety during running is the main feature of ○ ring rollers
- > Polymer bearing housing with precision ball bearing
- > Temperature range: -5° C to + 50° C
- > Bearing Housing – Polyamide black
- > ○ belt pulley – Polyamide, black
- > End Housing – Green

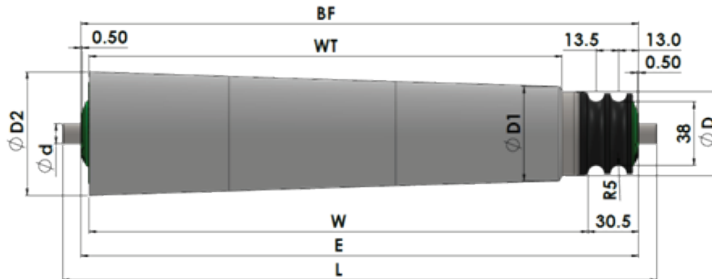

### 1403 Series – Spring Loaded

Tube Dia. (D)	Shaft Dia. (d)			
ø50	ø14	E = W+35	BF = W+36	L = W+56

Tube	D*T	WT	D1	D2	Shaft Dia. ø14	11 Hex
Steel, Zinc plated, tapered sleeve	50x1.5	300	ø56	ø74.9	1403-SHT-AJS	1403-SHT-AFS
		350	ø52.9	ø74.9		
		400	ø56	ø81.1		
		450	ø52.9	ø81.1		
		500	ø56	ø87.4		
		550	ø52.9	ø87.4		
		600	ø56	ø93.7		
		650	ø52.9	ø93.7		
		700	ø56	ø100		
		750	ø52.9	ø100		
		800	ø56	ø106.3		
		850	ø52.9	ø106.3		
		900	ø56	ø112.6		
		950	ø52.9	ø112.6		
		1000	ø56	ø118.9		
		1050	ø52.9	ø118.9		
1100	ø56	ø125.2				
1150	ø52.9	ø125.2				
1200	ø56	ø131.5				

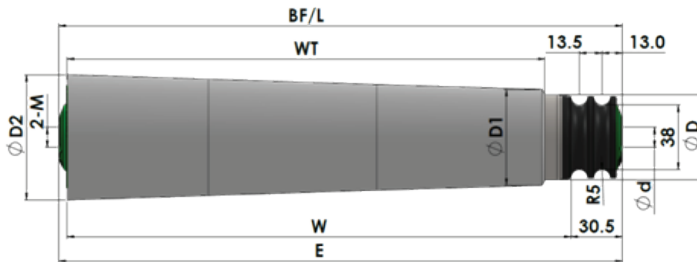

### 1403 Series – Internal Thread

Tube Dia. (D)	Shaft Dia. (d)			
ø50	ø14	E = W+35	BF = W+36	L = W+36

Tube	D*T	WT	D1	D2	Shaft Dia. ø14 (M8x20)
Steel, Zinc plated, tapered sleeve	50x1.5	300	ø56	ø74.9	1403-SHT-AJI
		350	ø52.9	ø74.9	
		400	ø56	ø81.1	
		450	ø52.9	ø81.1	
		500	ø56	ø87.4	
		550	ø52.9	ø87.4	
		600	ø56	ø93.7	
		650	ø52.9	ø93.7	
		700	ø56	ø100	
		750	ø52.9	ø100	
		800	ø56	ø106.3	
		850	ø52.9	ø106.3	
		900	ø56	ø112.6	
		950	ø52.9	ø112.6	
		1000	ø56	ø118.9	
		1050	ø52.9	ø118.9	
1100	ø56	ø125.2			
1150	ø52.9	ø125.2			
1200	ø56	ø131.5			

## 1404 Series

### POLY VEE PULLEY TAPERED SLEEVE ROLLERS

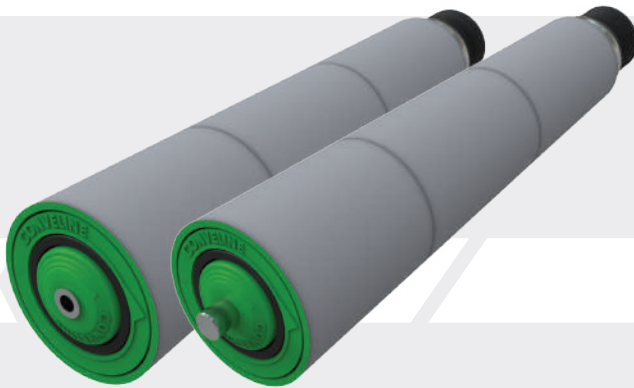

#### PRODUCT FEATURES

- > 1404 series poly vee belt pulley rollers with grey tapered sleeve
- > Polymer poly vee belt pully separates the drive area and conveying area
- > ISO 9982 PJ series poly vee pulley, Total 9 grooves at pitch of 2.34mm
- > Polymer bearing housing with precision ball bearing
- > Temperature range: -5° C to +50° C
- > Bearing Housing – Polyamide black
- > O belt pulley – Polyamide, black
- > End Housing – Green

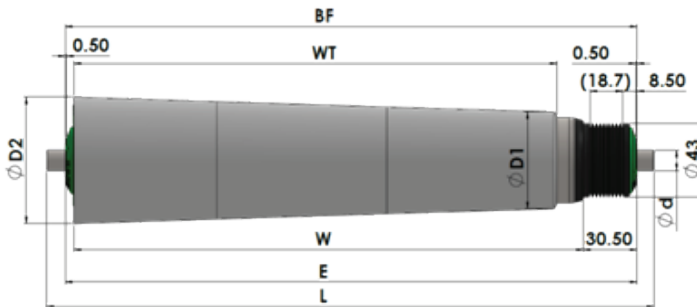

### 1404 Series – Spring Loaded

Tube Dia. (D)	Shaft Dia. (d)			
ø50	ø14	E = W+35	BF = W+36	L = W+56

Tube	D*T	WT	D1	D2	Shaft Dia. ø14	11 Hex
Steel, Zinc plated, tapered sleeve	50x1.5	300	ø56	ø74.9	1404-SHT-AJS	1404-SHT-AFS
		350	ø52.9	ø74.9		
		400	ø56	ø81.1		
		450	ø52.9	ø81.1		
		500	ø56	ø87.4		
		550	ø52.9	ø87.4		
		600	ø56	ø93.7		
		650	ø52.9	ø93.7		
		700	ø56	ø100		
		750	ø52.9	ø100		
		800	ø56	ø106.3		
		850	ø52.9	ø106.3		
		900	ø56	ø112.6		
		950	ø52.9	ø112.6		
		1000	ø56	ø118.9		
		1050	ø52.9	ø118.9		
1100	ø56	ø125.2				
1150	ø52.9	ø125.2				
1200	ø56	ø131.5				

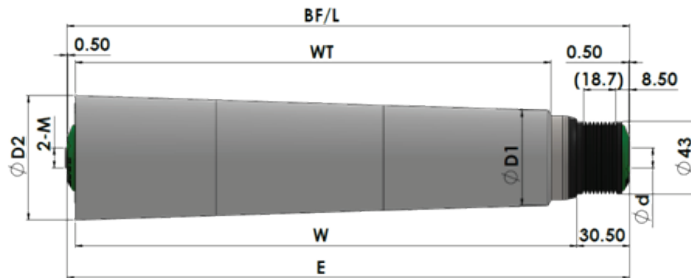

### 1404 Series – Internal Thread

Tube Dia. (D)	Shaft Dia. (d)			
ø50	ø14	$E = W + 35$	$BF = W + 36$	$L = W + 36$

Tube	D*T	WT	D1	D2	Shaft Dia. ø14 (M8x20)
Steel, Zinc plated, tapered sleeve	50x1.5	300	ø56	ø74.9	1404-SHT-AJI
		350	ø52.9	ø74.9	
		400	ø56	ø81.1	
		450	ø52.9	ø81.1	
		500	ø56	ø87.4	
		550	ø52.9	ø87.4	
		600	ø56	ø93.7	
		650	ø52.9	ø93.7	
		700	ø56	ø100	
		750	ø52.9	ø100	
		800	ø56	ø106.3	
		850	ø52.9	ø106.3	
		900	ø56	ø112.6	
		950	ø52.9	ø112.6	
		1000	ø56	ø118.9	
		1050	ø52.9	ø118.9	
1100	ø56	ø125.2			
1150	ø52.9	ø125.2			
1200	ø56	ø131.5			

## 1405/1406 Series

### POLYMER/STEEL SPROCKET TAPERED SLEEVE ROLLERS

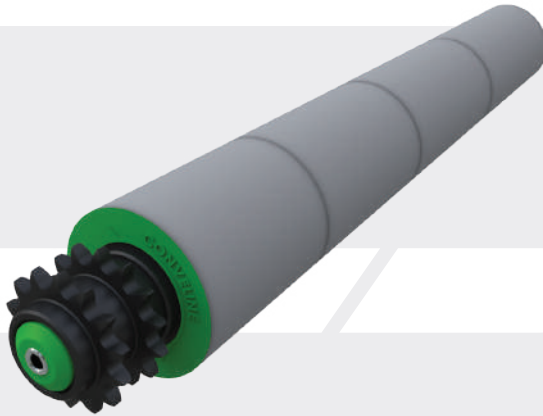

#### 1405-PRODUCT FEATURES

- > 1405 series polyamide double sprocket rollers with grey tapered sleeve
- > Low noise during running is the main feature of polyamide sprocket rollers
- > Roller pitch is limited
- > Polymer bearing housing with precision ball bearing
- > Temperature range: -5° C to + 50° C
- > Bearing Housing – Polyamide black
- > End Housing – Green

#### 1406-PRODUCT FEATURES

- > 1406 series steel double sprocket rollers with grey tapered sleeve
- > Polymer bearing housing with precision ball bearing
- > Temperature range: -5° C to + 50° C
- > Bearing Housing – Polyamide black
- > End Housing – Green

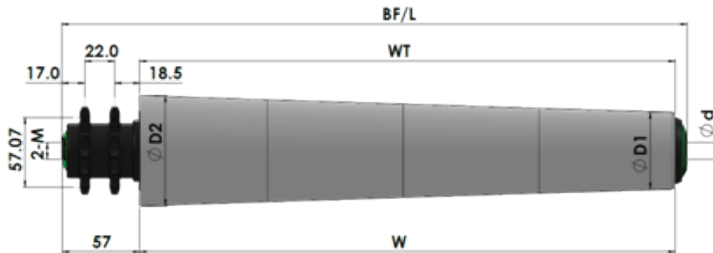

### 1405/1406 Series – Internal Thread

Tube Dia. (D)	Shaft Dia. (d)			Sprocket type
ø50	ø14	BF = W+62	L = W+62	08B14T

Tube	D*T	WT	D1	D2	Shaft Dia. ø14 (M10x15)
Steel, Zinc plated, tapered sleeve	50x1.5	300	ø56	ø74.9	1405-SHT-AJI/ 1406-SHT-AJI
		350	ø52.9	ø74.9	
		400	ø56	ø81.1	
		450	ø52.9	ø81.1	
		500	ø56	ø87.4	
		550	ø52.9	ø87.4	
		600	ø56	ø93.7	
		650	ø52.9	ø93.7	
		700	ø56	ø100	
		750	ø52.9	ø100	
		800	ø56	ø106.3	
		850	ø52.9	ø106.3	
		900	ø56	ø112.6	
		950	ø52.9	ø112.6	
		1000	ø56	ø118.9	
1050	ø52.9	ø118.9			
1100	ø56	ø125.2			
1150	ø52.9	ø125.2			
1200	ø56	ø131.5			

# CONVEYOR COMPONENTS

## BALL TRANSFERS & SKATE WHEELS

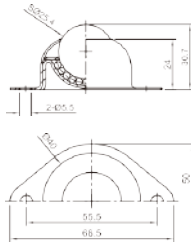

CA-01-A

- > Body and surface – steel, zinc plated
- > Static load – 25 kg
- > Dynamic load – 30 kg
- > Weight (gm) – 142

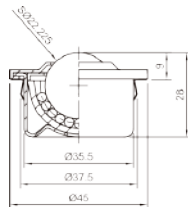

CA-01-B

- > Body and surface – steel, zinc plated
- > Static load – 40 kg
- > Dynamic load – 50 kg
- > Weight (gm) – 126

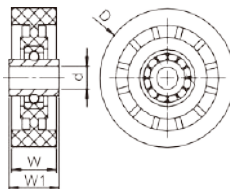

CA-01-C

- > Body and surface – ABS Plastic
- > Static load – 40 kg
- > Dynamic load – 60 kg
- >  $d = \varnothing 8.1$ ,  $D = \varnothing 48.5$ ,  
 $W = 16$ ,  $W1 = 18$

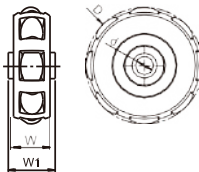

CA-01-D

- > Body and surface – POM+PA6 Plastic
- > Static load – 8 kg
- > Dynamic load – 10 kg
- >  $d = \varnothing 12.3$ ,  $D = \varnothing 51$ ,  
 $W = 16.5$ ,  $W1 = 20.5$

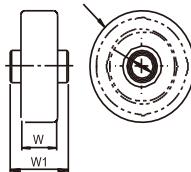

CA-01-E

- > Body and surface – Steel, zinc plated
- > Static load – 10 kg
- > Dynamic load – 15 kg
- >  $d = \varnothing 8.1$ ,  $D = \varnothing 49$ ,  
 $W = 16$ ,  $W1 = 20.6$

## CONVEYOR COMPONENTS

### SKATE WHEELS, FLOW RACKS, O – Ring

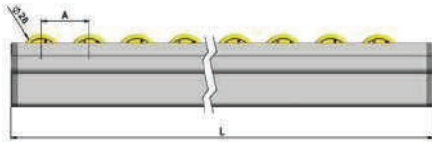

**CA-01-F**

- > Frame – Aluminum
- > Wheel – ABS
- > Load – 12.5 kg/m
- > Wheel pitch – 23.5

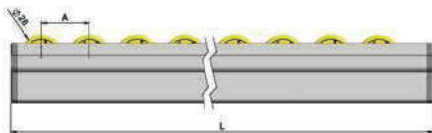

**CA-01-G**

- > Frame – Aluminum
- > Wheel – ABS
- > load – 12.5 kg/m
- > Wheel pitch – 23.5



**CA-01-H**

- > Type – Molded 5mm dia.
- > Material – PU, green
- > Suggested roller pitch – 75mm



**CA-01-I**

- > Poly vee belt + Pulley
- > Rib-2&3
- > Pulley also available on request
- > Overall length - As per requirement



**CA-01-J**

- > Sleeve material – PU
- > Dia. – 50 to 54
- > Thickness – 2mm
- > Color - grey

*Inspired by Excellence*



**CONVELINE SYSTEMS PRIVATE LIMITED**

BLOCK NO.472, Tajpur Road, B/h Unick Fix A Form,  
Changodar, Ahmedabad-382213,  
Gujarat, India

- +91 908 1915 912
- info@conveline.com, sales@conveline.com
- www.conveline.com, www.convelinerollers.com

**Need Something Different?**

Conveline sales team will provide you complete solution for your specific & custom application.